



**G-856AX Memory-Mag™
Proton Precession
Magnetometer**
P/N 18101-02 Rev. E

Operation Manual

GEOMETRICS, INC.

2190 Fortune Drive, San Jose, CA 95131

Phone: (408) 954-0522

Fax: (408) 954-0902

Email: sales@mail.geometrics.com

Web: www.geometrics.com

COPYRIGHT © 2007

Table of Contents

INTRODUCTION	1
WHAT IS A TOTAL FIELD MAGNETOMETER?	1
MAGNETOMETER APPLICATIONS	1
TERMS USED IN THIS MANUAL	2
THE G-856AX	2
MAGNETOMETER SET-UP	5
SENSOR FLUIDS	5
STANDARD SYSTEM ASSEMBLY	6
GRADIOMETER ASSEMBLY.....	10
BASE-STATION ASSEMBLY.....	13
SENSOR ORIENTATION	14
CONSOLE SET-UP	16
CONSOLE CONTROLS AND DISPLAY	16
SYSTEM CHECKOUT	17
OPERATING PROCEDURES	17
1 - Clearing a Key sequence	17
2 - Setting the internal clock	17
3 - Setting the Line Number Marker	18
4 - Manual Tuning of the Magnetometer	19
5 - Automatic tuning	21
6 - Acquiring and storing a magnetic field reading	22
7 - Recalling measurements from memory.....	22
8 - Erasing magnetometer readings	24
9 - Automatic reading set-up.....	25
10 - Retrieving magnetic field readings.....	26
FIELD OPERATION	29
SENSOR POSITION AND MEASUREMENT REPEATABILITY	29
MAGNETIC ENVIRONMENT	30
MAGNETIC SURVEYING.....	30
Standard operation.....	30
Gradiometer operation	32
DATA RETRIEVAL	33
COMPUTER CONNECTION AND DOWNLOAD	33
MANUAL TRANSCRIPTION	34
MAINTENANCE	35
INSTRUMENT STORAGE	35
VOLTAGE INDICATOR	35
BATTERIES	35
D-CELLS BATTERIES	36
GEL-CELL BATTERIES	37

LITHIUM BATTERY.....	37
SENSOR FLUID.....	38
APPENDIX.....	41
MAGNETIC FIELD INCLINATION (DEGREES)	41
MAGNETIC FIELD INTENSITY VARIATION (NT)	41
TROUBLESHOOTING.....	42
RS-232 INTERFACE.....	43
FRONT PANEL CONNECTOR PIN ASSIGNMENT	44
OUTPUT FORMAT	44
EXTERNAL POWER	45
EXTERNAL MAGNETOMETER CONTROL.....	45
INTERNAL PROGRAMMING SWITCHES	46
<i>Polarize and count time – Switches 1 through 4</i>	47
INTERNAL RESET SWITCH	49
SPECIFICATIONS	50
WARRANTY AND SERVICE.....	52
DECLARATION OF CONFORMITY.....	54

Table of Figures

Figure 1. G-856 proton-precession magnetometer.....	6
Figure 2. Sensor staff sections.....	7
Figure 3. Sensor preparation.....	7
Figure 4. Staff / sensor assembly.....	8
Figure 5. Console battery compartment.....	8
Figure 7. G-856 shoulder harness.....	9
Figure 8. Assembled magnetometer.....	9
Figure 9. Location of 'Read' key on magnetometer console.....	10
Figure 10. Gradiometer components.....	10
Figure 11 Removing standard sensor cable from top sensor.....	11
Figure 12. Top sensor with gradiometer cable attached.....	11
Figure 13. Bottom sensor with gradiometer cable attached.....	11
Figure 14. Connection of threaded staff adaptors.....	12
Figure 15. Completed gradiometer staff.....	12
Figure 16. Attach the gradiometer switch box.....	13
Figure 17. Base-station setup up using tripod kit and G-856AX staff section.....	14
Figure 18. Alternate orientation for G-856AX sensor mount.....	15
Figure 19. Magnetic Inclination of the Earth's field.....	15
Figure 20. G-856AX console display and keypad.....	16
Figure 21. Magnetic Field Intensity Variation, (nT).....	20
Figure 22, Typical survey layout.....	31
Figure 23. Location of console's internal programming switch.....	46
Figure 24. Internal reset switch.....	50

List of Tables

Table 1. An example of the console memory stack.	23
Table 2. Battery endurance comparison.	36
Table 3. RS-232 cable connector pin assignment.	43
Table 4. Summary of programmable switch settings.	47

Introduction

This manual provides operating instructions for Geometrics G-856AX portable proton-precession magnetometer. It includes step-by-step instructions on magnetometer set-up, survey usage, measurement data retrieval, and maintenance.

What is a total field magnetometer?

A total magnetometer is an instrument that measures the scalar intensity of the local magnetic field. The G-856AX relies upon the proton-precession measurement technique. This technique makes use of an induction coil to create a strong magnetic field around a hydrogen-rich fluid such as Kerosene. This causes the hydrogen protons to align or polarize their spin axis with the newly applied magnetic field. When the current producing the polarizing field is interrupted, the protons begin to align themselves with Earth's magnetic field but in doing so will momentarily precess about the earth's field at a specific frequency that is proportional to the ambient magnetic field intensity. This precession generates a small magnetic field that induces an alternating voltage in the induction coil that was previously used to generate the polarization field. The relationship between the precession frequency of the induced voltage and the strength of Earth's magnetic field is called the proton gyromagnetic ratio and is equal to 0.042576 hertz per nanotesla (Hz/nT).

Magnetometer applications

Most rocks contain some magnetite, hematite or other magnetic material and will produce disturbances in the local magnetic field. Because of this, most soils and many man made objects that contain iron or nickel have magnetic properties detectable by a sensitive magnetometer because they create local or regional anomalies in the Earth's main field. Anomalies are revealed by systematic measurement of the variation in magnetic field strength with position.

Interpretation of magnetometer readings allows the surveyor to make inferences about what exists beneath the Earth's surface. Based on experience with the survey area, the surveyor might interpret the measurements to indicate to location of a pipeline, fired pottery or bricks, a piece of ordnance, a particular mineral, or geologic structure. The interpretation of magnetic survey results is sometimes a difficult task, made even more complex by constant changes in the earth's overall magnetic field, the size and distance of objects from the magnetometer, the amount of magnetic material the object contains, as well as the magnetic susceptibility of the object and the host material. On the other hand, in many applications, simple interpretations of anomalous magnetic fields will lead to a straight forward understanding of the source of the anomaly.

The proton precession magnetometer is one of the principal instruments for magnetic surveys because it combines high accuracy and ease of use. The [Applications Manual for Portable Magnetometers](#), supplied with this instrument and available for download from

our website includes general information on the use of magnetometers. It should be studied as a companion to this manual which deals specifically with the G-856AX Memory Mag™.

Terms used in this manual

The magnetic field intensity at the surface of the Earth has an average value of about 50,000 nano-Tesla (nT). Historically, one nT is sometimes referred to as a gamma or “ γ ”. Throughout this manual we will always express field intensity in nT.

The terms “sampling”, “cycling”, and “reading” all refer to the magnetometer’s measurement of the field intensity. Note that these terms do not necessarily refer to both measurement and internal storage of the measurement value.

The G-856AX

Depending on its particular configuration, the G-856AX can be a portable, man-carried magnetometer, a gradiometer measuring the field with two sensors, or a "base station" magnetometer. As a hand-carried instrument, it features simple, push button operation and a built-in digital memory that stores over 5000 single sensor measurements or 2500 gradiometer readings. This relieves the user of the need to physically write down the data in the field, eliminates transcription errors and most importantly, allows the use of computers to automatically record and process the data from the magnetic survey. Software Programs are available from Geometrics to help the user process and interpret survey data. These programs include MagMap2000 and MagPick and are available for download from our website: www.geometrics.com.

The G-856AX can also record data automatically at regular intervals, so it can be left unattended to monitor diurnal changes in the earth's magnetic field. These readings (up to 12,500) are collected at a base station and used to correct simultaneous field measurements for high accuracy surveys. Measurement data from the G-856AX may also be fed directly into an external computer. The time-of-day generated by the magnetometer’s internal clock is recorded with each reading taken in either mode.

All operations are controlled from keys imbedded in a weatherproof membrane that comprises the magnetometer console’s front panel. The key sequences for the various magnetometer operations have been carefully designed to provide simple yet flexible operation.

A single connector is used for the sensor signal input and data output. The output format is in the universal RS-232 protocol that is accepted by most modern computers. Interface software for downloading, profiling and gridding/contouring of data is provided by Geometrics MagMap2000 software. A serial to USB converter is available for use with computers that are not equipped with a serial port.

Physically, the G-856AX is compact and lightweight. It is weather proof and operates

over a wide temperature range. Depending on the model version, it is powered either by nine (9) D-cell batteries or, more commonly, by an internal rechargeable lead acid gel cell battery.

Unlike other proton-precession magnetometers, the G-856AX has an internal programming switch allows modification of the magnetometer's cycle times to ensure that it will work properly anywhere in the world.

Above all, the G-856AX is a high-precision magnetometer, the result of many years experience in the manufacture of similar instruments. The operation of the instrument is controlled by a microprocessor and the control program may be changed at any time for product improvement or other considerations. In that event, you may find variations between this manual and the operation of your actual instrument operation. Such variations will have no adverse effect and should be recognizable as you familiarize yourself with operation.

Magnetometer Set-up

The standard G-856AX system is used as a mobile instrument for measurement of the magnetic field intensity sequentially at discrete locations. With the appropriate accessories the standard system can be configured for measurement of the differential magnetic field (gradient) over the survey area or the magnetometer can be set up to record the temporal changes in the magnetic field intensity at a fixed point to acquire base station measurements.

Sensor fluids

The sensor contains coils of insulated wire and for optimum operation these coils must be submerged in a hydrogen-rich fluid. The following section provides information about this fluid and the correct procedure for filling the sensor with fluid.

It is important that you DO NOT operate the sensor for an extended period without fluid as this can damage the sensor. The sensor should be filled so that the fluid level is about 1cm below the fill port. There is a fill port tube inside the sensor that provides for an air gap when the sensor is filled. Correct fluid level can be checked approximately by shaking the sensor and judging the fluid level by the degree of sloshing. A more accurate level check requires removal of the sensor's fill plug and visual inspection of the contents. If the sensor is empty or needs filling proceed as follows:

- A. Place the sensor on a flat, level surface.
- B. Remove the blue cap plug on the sensor. Observe that the fill-port is a threaded tube extending into the sensor vessel. This design provides a 1cm air gap that allows for thermal expansion of the sensor fluid.
- C. Fill with acceptable sensor fluid to within 1 cm. from the top. Acceptable fluids for proton-precession magnetometers include:
 - Shell SOL-71 (Shell Oil Co. product).
 - Charcoal Lighter Fluid (Kingsford, Wizard, etc.)
 - n-Decane (chemical supply houses, oil refineries)
 - ISOPAR-1 (Exxon Oil Co. product)
 - Odorless Mineral Spirits (also known as Naptha)
 - Kerosene
- D. Pour only clear fluid into the sensor. If fluid is dirty use a paper coffee filter or fine screen to eliminate particles.
- E. Slowly pour fluid into sensor until it is full. The sensor is full when the fluid just reaches the bottom of the fill-port as described above.
- F. Place Teflon™ tape around the fill plug then screw it into the fill-port and tighten. Note: the fill plug and fill-port have tapered threads designed to form a tight seal. Tighten the plug just enough to prevent leakage - over tightening may crack or damage the sensor housing.
- G. Sensor is now ready for use.

The different sensor fluids listed above will provide slightly different signal amplitudes but their use will ensure that the magnetometer measures the magnetic field strength correctly and that the sensor will not be damaged interaction with the fluid. *Geometrics does not recommend the use of gasoline (petrol) as a sensor fluid. Experience as shown that local formulation of gasoline may include additives that can damage the sensor. Do not put any solvent containing acetone or toluene into the sensor: these will dissolve the sensor body.*

Standard System Assembly

As shown in Figure 1 the standard G-856AX comes packed in a durable plastic carrying case, with compartments for its accessories. It contains:

- G-856AX console
- Sensor
- Sensor signal cable
- Aluminum staff (four (4) mating sections)
- Console chest harness
- Two (2) rechargeable lead acid battery packs and charger (or D-cell alkaline batteries, nine (9) required)
- G-856 Operator's Manual (on CD)
- Application Manual for Portable Magnetometers (on CD)
- MagMap2000 Software and Manual (on CD)
- RS232 Data Output Cable

If the magnetometer is new it was shipped without sensor fluid. Before the magnetometer will operate correctly the sensor must be filled with the appropriate fluid. See the preceding section for a list of appropriate sensor fluids.



Figure 1. G-856 proton-precession magnetometer.

Assembly of the magnetometer is quite simple. Proceed as follows referring to Figure 2 through Figure 8.

- 1) Assemble the staff by inserting each section into the next twisting them until they are locked. As shown in Figure 2a, there are four staff sections. The section with the rubber tip is the bottom section and the section with the threaded end is the top section. Figure 2 b shows the cam-lock end of the staff section. This end is inserted into the open end of the matching section. Twisting the jointed sections by $\frac{1}{4}$ turn will lock them together.

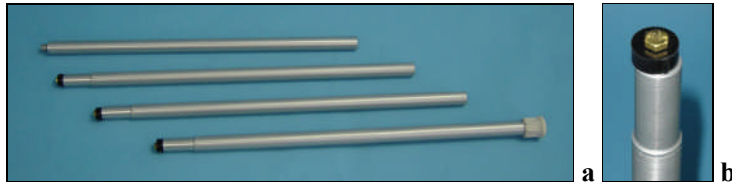

Figure 2. Sensor staff sections.

- 2) Verify that the sensor contains fluid. You may shake the sensor to determine if it contains fluid. A sloshing sound indicates proper filling. Some air space above the fluid needed for thermal expansion - see instructions on sensor fluids in this section for details. Figure 3 shows the location of the sensor fluid fill port and the mounting points of the sensor cable. Any tools used for adding fluid, tightening fasteners or the port plug should either be non-magnetic or have a clean, rust free hard-chromed finish.

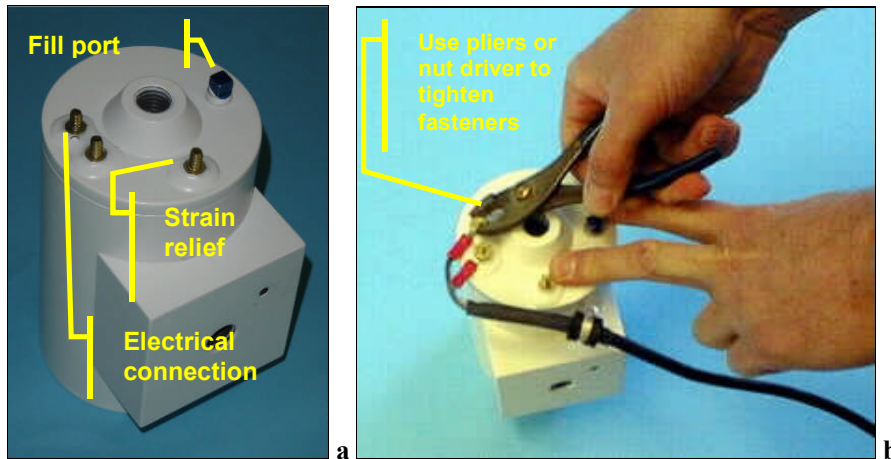

Figure 3. Sensor preparation.

Note: Geometrics recommends using non-magnetic tools for this task and it is important to use the original brass nuts and washers supplied with the instrument as substitutes could be contaminated with ferrous material.

- 3) Mount the sensor on the threaded staff section. As shown in Figure 4a and b, there are two ways the sensor can be mounted, either vertically, on its end or

horizontally on its side. For now, mount it vertically as shown in Figure 4 a.

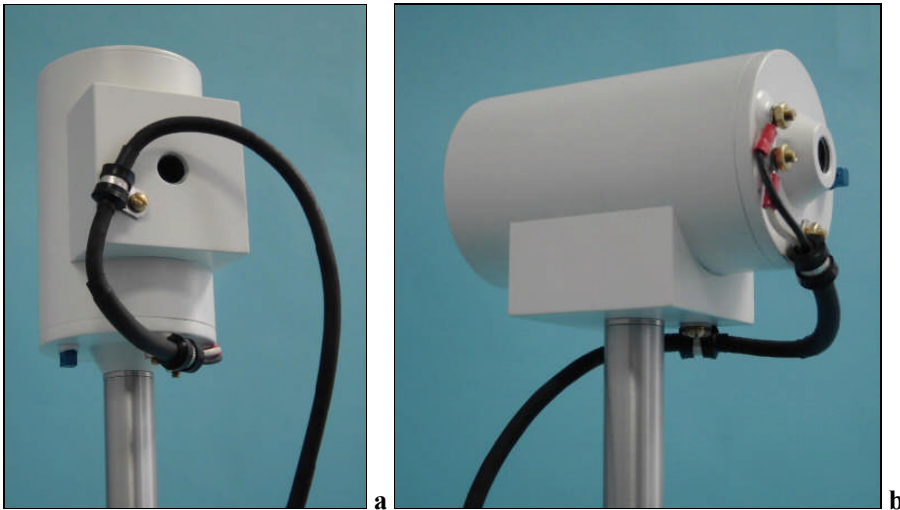

Figure 4. Staff / sensor assembly.

- 4) Remove the console cover by flipping the plastic tabs on its sides outward and sliding the cover completely off as shown in Figure 5 \a and b. Depending on the G-856AX version either a) Install fresh D-cell alkaline batteries or b) connect the internal rechargeable gel-cell battery. Gel-cell batteries are held in place with Velcro straps as shown in Figure 5c. Reinstall the cover before proceeding.

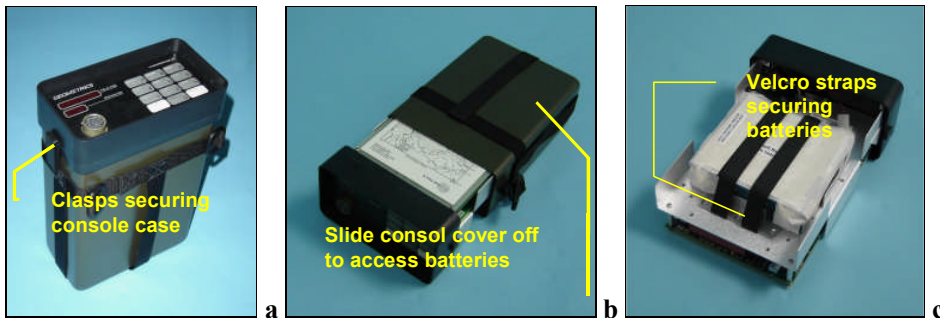

Figure 5. Console battery compartment.

- 5) The magnetometer is shipped with the signal cable attached to the sensor. If this cable is not connected to the sensor connect it as shown in Figure 3b. The sensor cable terminals are secured to the studs with brass washers and brass nuts. Do not substitute other hardware for these parts unless then completely non-ferrous. Tighten the terminal nuts finger-tight and then tighten an additional 1/8th turn (between 18 in-lb and 24 in-lb). Connect the signal cable to the magnetometer.
- 6) Put the console harness on as shown in Figure 6a. Hold the console to your chest

and clip the shoulder strap to the D-ring on the console holster as shown in Figure 6b. Do the same with the waist strap and then repeat this procedure on the other side of the holster. Adjust the harness so that the console is centered on your torso as shown in Figure 6c.

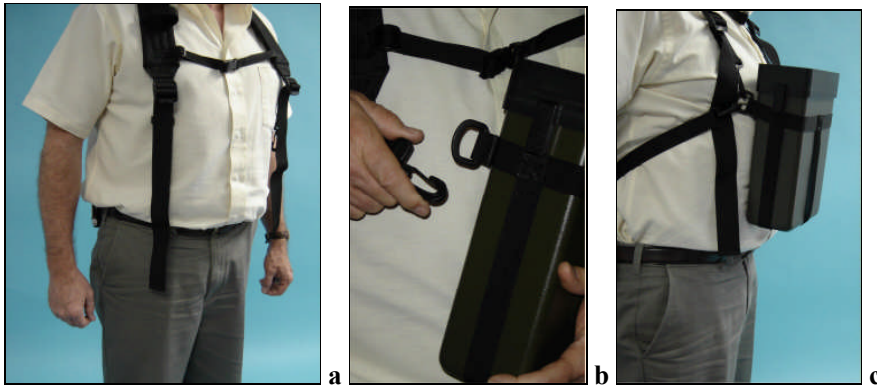

Figure 6. G-856 Shoulder harness.

- 7) Raise the sensor staff assembly to a vertical position and hold it steady for 3-4 seconds before taking a reading. Figure 7a shows the completed assemble ready for measurement. Figure 7b shows an alternate method for carrying the staff with the sensor with its central axis vertical. This method uses the saddle mount as the attachment point for the staff and will require a non-magnetic counter weight (available from the factory).

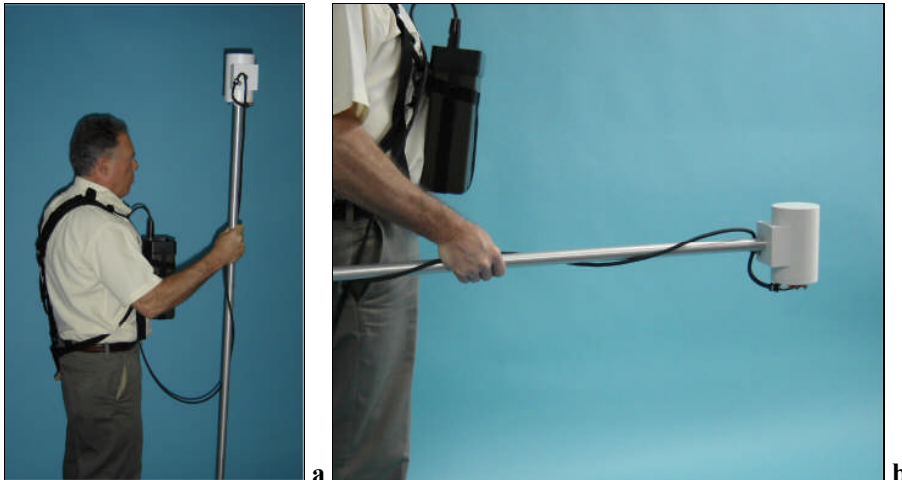

Figure 7. Assembled magnetometer.

- 8) Verify that the console is powered and properly connected to the sensor by momentarily depressing the **READ** key. The position of this key is shown in Figure 8. The displays will light, turn off, then light again for 5 seconds. If the

displays did not light, check battery power or the Troubleshooting section in this manual.

Comment [jj1]:



Figure 8. Location of 'Read' key on magnetometer console.

Gradiometer Assembly

G-856AX gradiometer operation requires an optional set of accessories. These items are shown in Figure 9 and include:

- Gradiometer sensor
- Lower staff adapter
- Upper staff adapter
- Gradiometer sensor cable
- Gradiometer Switch
- Velcro attachment pack



Figure 9. Gradiometer components.

Proceed with gradiometer assembly as follows:

- 1) Start by removing the standard (single sensor) cable from the top sensor. This will require removal of the sensor clamp and brass stud nuts as shown in Figure 10a and b.

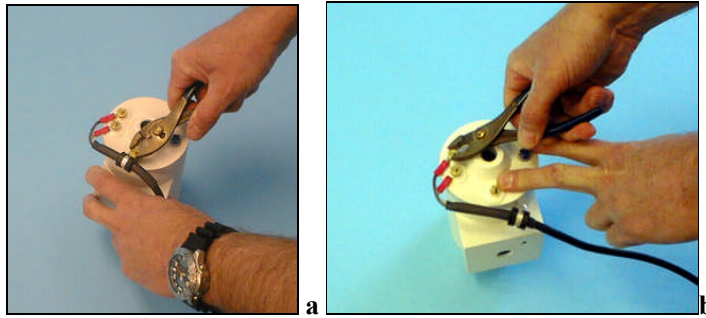

Figure 10 Removing standard sensor cable from top sensor.

Note: Geometrics recommends using non-magnetic tools for this task and it is important to use the original brass nuts and washers supplied with the instrument as substitutes could be contaminated with ferrous material.

- 2) Attach one of the thinner gradiometer sensor cables to the top sensor as shown in Figure 11 using the stud nuts washers and clamp that secured the standard cable.



Figure 11. Top sensor with gradiometer cable attached.

- 3) As shown in Figure 12, attach the other gradiometer sensor cable to the bottom sensor in the same manner used on the top sensor.



Figure 12. Bottom sensor with gradiometer cable attached.

- 4) Next, connect the threaded staff adaptors parts to the top of one staff section and the bottom of another staff section as shown in Figure 13 a. The bottom sensor is configured with opposing mounting points and the adaptors should be screwed into one set of these mounting points as shown in Figure 13 b.

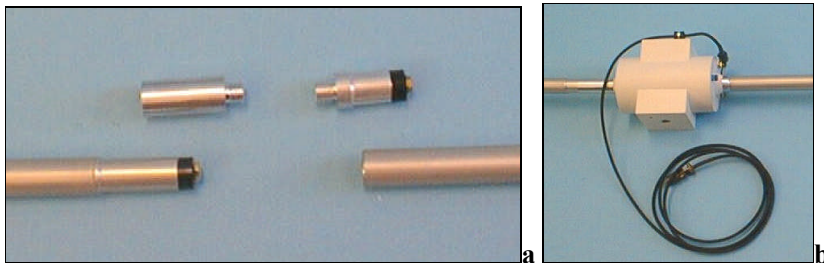

Figure 13. Connection of threaded staff adaptors.

- 5) The separation between gradiometer sensors is determined by the lengths and number of the staff sections linking the sensors. The minimum separation will always include one of the threaded adaptors and the top (threaded) staff section as shown in Figure 14 a. Typical sensor separation will be two staff sections (4ft.). Note that Figure 14a shows only one staff section separating the sensors. Normally, two staff sections will support the bottom sensor so that the top sensor is at 8 ft and the lower sensor at 4 ft. An alternative configuration is shown in Figure 14b where three staff sections support the lower sensor. With any gradiometer configuration it is best to hold the staff at arms length when measuring the gradient. This will prevent the lower sensor from coming too close to the console and better isolate it from the magnetic effects of the system circuitry and batteries.

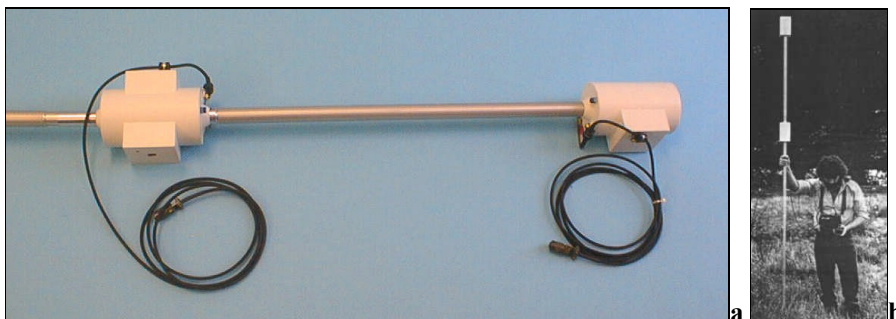

Figure 14. Completed gradiometer staff.

- 6) The sensor cables may now be connected to the Remote Start Switch box, and the Remote Start Switch may be connected to the G-856AX front panel connector. As shown in Figure 15, attach the Velcro strip to the top of the G-856AX black front panel bezel. Mount the Remote Start box to this mating Velcro strip.

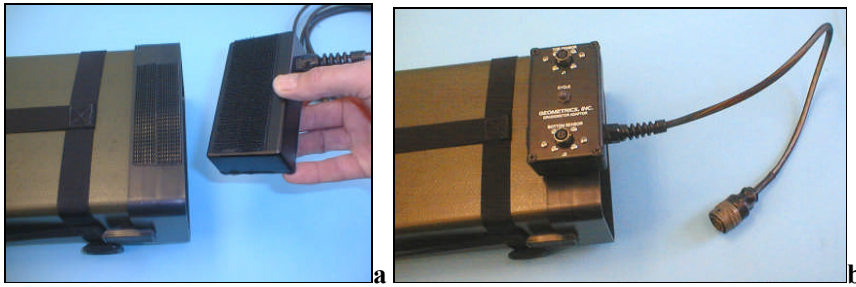

Figure 15. Attach the gradiometer switch box.

Base-station Assembly

The effects of the diurnal variation of the Earth's magnetic field can be removed from survey measurements if measurements were made during the survey with a base-station magnetometer. This magnetometer operates in a fixed location while the survey magnetometer is used to acquire magnetic field measurements over the survey area.

In order to provide a useful base-station reference, the base-station magnetometer sensor should be positioned at least 1 m above the ground surface and well away from moving magnetic objects or structures that will generate a strong magnetic gradient. The sensor should also be mounted on a stable structure in order to minimize wind-induced motion of the sensor. Geometrics provides a base-station kit that can be used with the G-856AX staff sections to construct a stable base-station tripod.

The tripod kit includes a tripod base and two (2) leg tips. The tripod assembly is shown in Figure 16 with sensor attached. Here, the bottom staff section and the two middle staff sections have been inserted into the three inclined holes on the underside of the tripod base. Leg tips have also been slipped on the ends of the two middle staff sections. Attach the sensor to the top staff section before inserting this piece into the tripod base. The top staff section is inserted into the central hole on the top of the tripod base so that it slides past the internal O-ring and rests on the bottom of the hole. The O-ring will prevent the sensor from rotating under the influence of the wind.

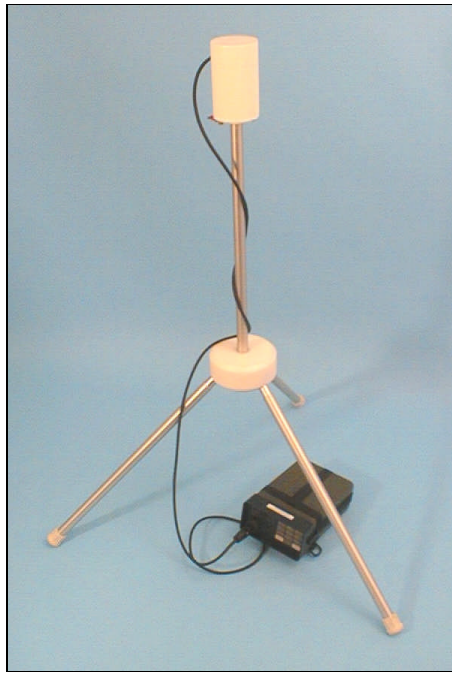

Figure 16. Base-station setup up using tripod kit and G-856AX staff section.

Sensor orientation

The G-856AX sensor may be mounted on the sensor staff in either of two orientations: 1) vertically, so that the cylindrical axis of the sensor is parallel to the sensor staff or 2) horizontally so that the sensor axis is perpendicular to the sensor staff. This is accomplished by screwing the sensor staff into either of the threaded receptacles in the standard sensor body. These receptacles are shown in Figure 17 a. End mounting is shown Figure 17 b and saddle mounting in Figure 17 c. These alternative modes of mounting the sensor allow the G-856AX to be configured for use anywhere in the world. Horizontal and vertical mounting is also accommodated on the gradiometer sensor.

When making a measurement, the correct sensor orientation will be determined by the Earth's magnetic field inclination in the survey area. In regions where the magnetic inclination is greater than $\pm 40^\circ$ the sensor should be end-mounted if the measurement is made with the sensor staff held vertically. That is, the sensor should be mounted so that its cylindrical axis is vertical. Note that in this configuration the sensor has a North arrow on its top surface. This arrow should be directed toward magnetic north when taking a measurement. Aligning the sensor this way will place the axis of the sensor's internal coils perpendicular to the Earth's field and produce optimum signal.

When surveying in regions where the Earth's field is inclined at less than $\pm 40^\circ$ the sensor should be mounted with its cylindrical axis horizontal as shown in Figure 18c.

This will orient the sensor coils for maximum signal when the magnetic field has low inclination.

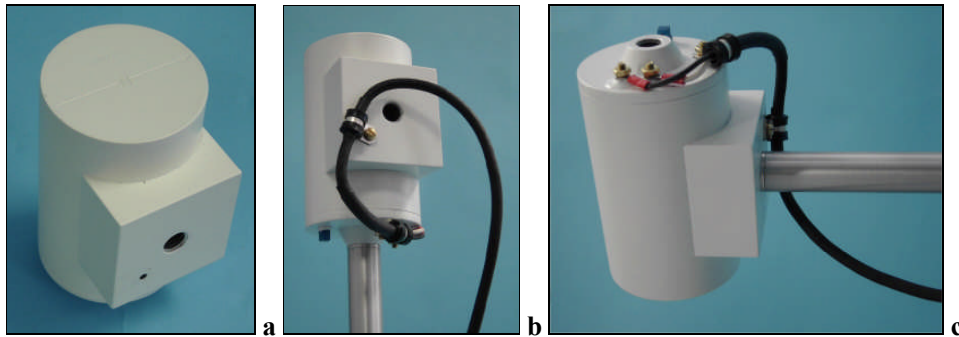

Figure 17. Alternate orientation for G-856AX sensor mount.

The G-856AX staff can be positioned horizontally or vertically when taking a measurement. If the staff is held vertically then the sensor should be attached as show in Figure 18. If, on the other hand, the staff is held horizontally during measurement, the mounting points should be reversed. That is, the sensor should be attached at the saddle mount in regions of high inclination and end mounted in low inclination regions.

Figure 18 is a map showing worldwide variation of the magnetic inclination. When used in the green-shaded regions shown in Figure 20, the sensor's cylindrical axis should be oriented vertically. Outside of this green region the sensor should be mounted so that its cylindrical axis is horizontal.

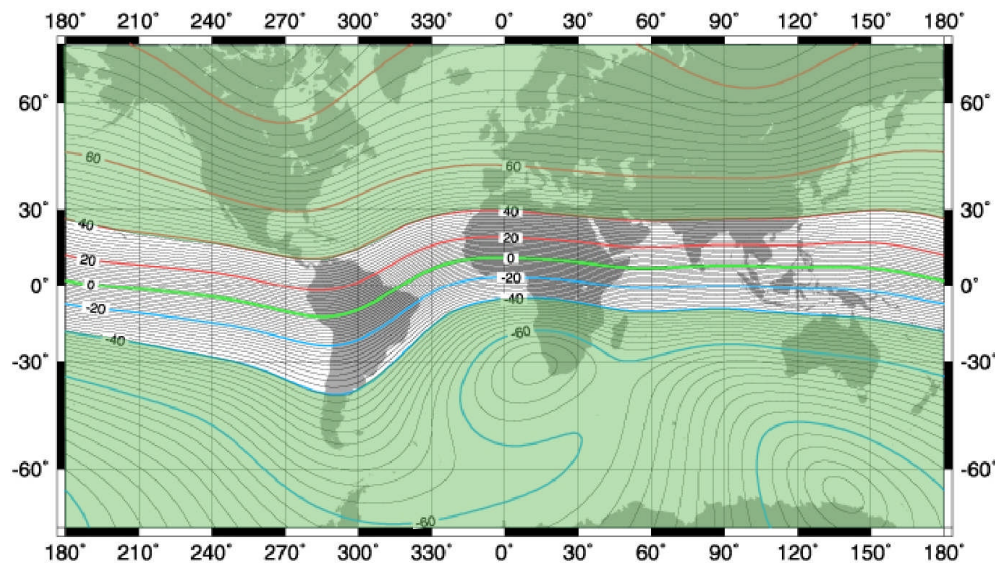

Figure 18. Magnetic Inclination of the Earth's field.

Console Set-up

Console controls and display

The console is controlled from a 12-key keypad located on its top surface and shares this space with the LED display and sensor connector as shown in Figure 19. Each control key has one or more functions and all but two of the keys are also used for numeric input.



Figure 19. G-856AX console display and keypad.

Note that the keys are labeled according to their function and numeric input value. The functions of the keys are summarized as follows:

- **RECALL** - Accesses the console memory. Also decrements memory location displayed.
- **STORE** - Stores measurement in memory
- **READ** - Makes a measurement of the magnetic field.
- **FIELD** - Used during memory recall to recover the field reading after TIME has been depressed.
- **TIME** - Accesses the real time clock. Also displays the time at which readings were taken.
- **TUNE** - Displays and/or sets the magnetometer tuning. Provides display of the signal strength received from last reading.
- **OUTPUT** - Begins automatic output of stored data to external device.
- **AUTO** - Starts and stops automatic recording. Sets interval for automatic recording.
- **ERASE** - Erases a reading, the last group of readings, or the whole data memory. (Must depress twice to erase all data).
- **CLEAR** - Clears a keystroke or keystroke sequence.
- **SHIFT** - Accesses the key's numeric value instead of its function.
- **ENTER** - Designates the end of a key sequence and transfers command to console's processor. Also increments memory location displayed during recall operations (see RECALL).

The display functions are as follow:

- **FIELD/TIME** - Displays the magnetic field or the time
- **STATION/DAY** - Displays the station number, also the Julian Day, or the line number.
Also displays signal strength, tuning and battery voltage.

System checkout

The G-856AX can be quickly checked for proper operation. This checkout should be done out of doors some distance away from buildings, power lines, vehicles, or other structures that will generate significant magnetic fields. Use the following procedure to verify that the magnetometer is operating correctly.

- 1) Assemble the staff sections as described above in Magnetometer Setup.
- 2) Make sure that the sensor is filled with fluid. You can shake the sensor to determine if it is adequately filled.
- 3) Mount the sensor on the staff or tripod.
- 4) Open the console case by releasing the plastic snaps on it sides and slide the cover off of the console. Verify that the batteries are correctly oriented (D-cells) or that they are connected (rechargeable Gel-cells). Reinstall the console cover.
- 5) Attach the sensor signal cable to the console's connector.
- 6) Depress the **READ** key. The displays should light, turn off, then light again for 5 seconds showing the measured magnetic field strength. If the displays did not light or if the indicated field strength appears to be incorrect see the Troubleshooting section in this manual.

Operating procedures

The G-856 is quite simple to operate. Most of the controls will not be used during the course of a normal survey. The following is a detailed description of the operating procedure associated with each key function.

1 - Clearing a Key sequence

To clearing a keystroke or keystroke sequence depress:

CLEAR

When you depress **CLEAR** the displays will go blank and any keystroke(s) you have entered will be erased.

2 - Setting the internal clock

To set the magnetometer's internal clock to the Julian date and time press:

AUTO, **TIME**, **SHIFT**

Then press: 'day', 'day', 'day',
and then press 'hour', 'hour', 'minute', 'minute', **ENTER**.

The Julian date is the number of days since the beginning of the year. For example, the Julian date for February 10 is 41. To enter the date and time corresponding to 10:35AM on February 10 you would key **AUTO**, **TIME**, **SHIFT**, '0','4','1','1','0','3','5', **ENTER**.

There are a number of features related to the internal clock, and they are discussed at several places in this manual. It is especially important to set the clock properly when diurnal corrections will be applied to your survey measurements because the survey and the base station magnetometer clocks must be synchronized with each other for the correction to be effective. The console's date and time setting will be used in post-acquisition processing with the MagMap2000 software. The recommended procedure for insuring correct internal clock synchronization is as follows:

- Check the clock to see if it needs setting. Do this by pressing **TIME**. The hour, minutes, seconds will light in the FIELD/TIME display and you should see that the seconds are advancing. The Julian date will be indicated in the STATION/DAY display. Compare the magnetometer clock's time to your watch, time standard, or your base station instrument and decide whether you need to reset the clock. Note that the display will automatically go blank 5 seconds after pressing **TIME**.
- If you decide that you need to reset the clock, choose a time in the near future when you plan to start the G-856AX clock. Then proceed with the clock setting sequence (**AUTO**, **TIME**, **SHIFT**, 'day', + 'day' + 'day' + 'hour' + 'hour' + 'min.' + 'min.'). Now, wait for real time to match your clock setting. At the instant the display matches the real time standard press **ENTER**. When you do this, the new setting will be entered and the display will go blank.

Note that G-856AX clock time does not change until you press **ENTER**. If you make a mistake in the time entry sequence, just press CLEAR and you will see that the old time setting is still active.

Pressing **ENTER** just after the Julian Date is keyed in will change this number without resetting the clock. In Automatic Mode the magnetometer will increment this number every 24 hours as described below under Item 9 - Automatic reading set-up.

3 - Setting the Line Number Marker

If the magnetometer is not in Automatic Mode (collecting measurements as a base-station instrument) then it is in Survey Mode. In Survey Mode you are provided with a means of designating the current survey line with a line number that will be stored in console memory. Each measurement that you acquire in Survey Mode will be designated by its line and station number. (See Magnetic Surveying, in the Field Operation chapter for further details). When in Survey Mode, a three-digit number indicating the line number appears in the STATION/DAY display when the **TIME** key is depressed. When in

Automatic Mode, the three-digit number appearing when **TIME** is depressed is the Julian day of the year.

In Survey Mode both the current line number setting and the Julian day are recorded for each reading taken, although both are not available for viewing on the displays. Nevertheless, the G-856AX data file contains both of these items and the measurement value. That is, the line number, the time and Julian day, the field reading, and the station number are all retained in the console memory.

Be sure you are not in Automatic Mode when setting the line number.

To change the line number press:

TIME, **SHIFT**, 'n','n','n', **ENTER**

The display will go blank and the new line number (nnn) will be applied to the magnetic field reads that are subsequently stored. Press **TIME** to verify that the desired line number is currently in use. The value line number will be shown in the STATION/DAY display.

4 – Manual Tuning of the Magnetometer

The magnetometer needs to be tuned in order to provide its amplifier circuits with the greatest signal strength and thereby provide the best sensitivity. The tuning procedure is a matter of matching the console's internal tuning frequency to the actual proton-precession frequency corresponding to the local magnetic field strength.

Usually, fairly accurate readings can be obtained if the magnetometer is tuned to be within 3,000 nT of the local magnetic field strength. The approximate magnetic field in your survey area can be obtained by examining the world magnetic map provided in Figure 20 and in the Appendix of this document. This world map is overlain with contour lines showing the regional variation of magnetic field strength with position. Simply find your position on the map and read the field strength on the nearest contour line.

At the beginning of a new survey we recommend that you check the magnetometer's tuning and, if necessary, adjust it to obtain maximum signal strength. Check the magnetometer's tuning by pressing and releasing the **TUNE** key. You will see something like the following:

51G 1.7	FIELD/TIME STATION/DAY
--------------------------	---------------------------

After about one second this display will be succeeded with something like:

tunE	FIELD/TIME
-------------	------------

Initially, the Field/Time displays 'SIG' indicating the signal strength in the STATION/DAY display. Signal strength is reported as a number ranging from 0.0 to a maximum of 9.9. The 'tunE' display that succeeds the signal strength display shows the current tuning in terms of magnetic field intensity with units of 100 nT. For example, if the display shows '560' then 56,000 nT tuning is indicated.

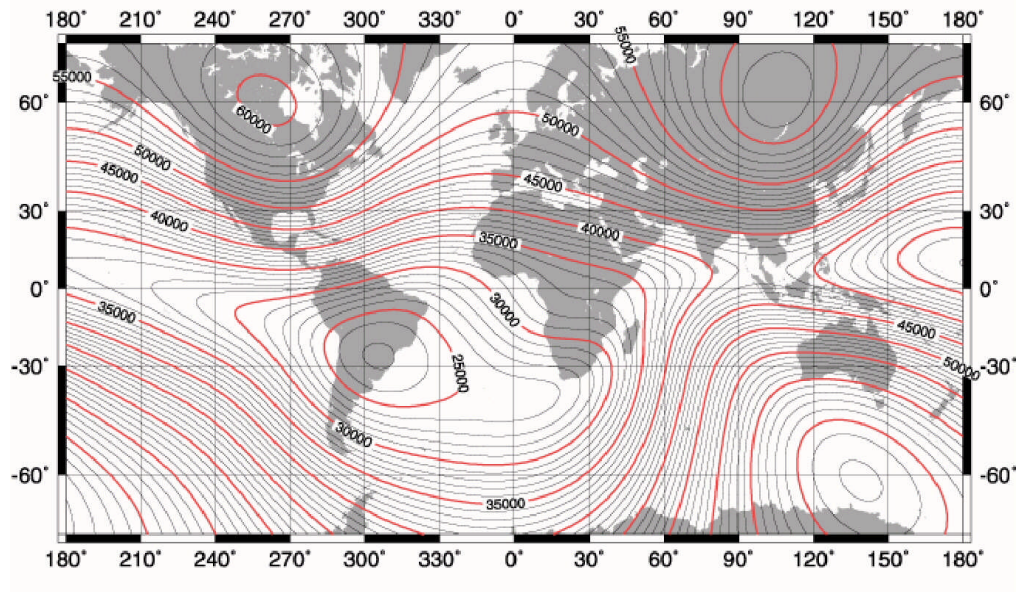

Figure 20. Magnetic Field Intensity Variation, (nT)

The objective in tuning the magnetometer is to adjust the magnetometer's tuning (as indicated under '**tunE**') to obtain a reasonable signal strength (as indicated under '**SIG**') Approximate tuning will be adequate for most surveys but the G-856AX does allow you to tune the magnetometer very precisely - the magnetometer may be tuned to 3-digit resolution from 256 possible tune values ranging from 20,000 and 90,000 nT.

When attempting to tune the magnetometer you should be outdoors, away from power lines and large metal objects. Use the following procedure to tune the magnetometer:

- 1 Use the world magnetic map (Figure 20) to determine the approximate field strength for your location.
- 2 Press **TUNE**, **SHIFT**, 'n', 'n', 'n', **ENTER** where 'nn.n' is the regional field strength in μT (micro Tesla, the three most significant digits of the full reading in nT).
- 3 Press **READ** to take a reading and note of its value.
- 4 Press and hold **TUNE** and note the signal level (number between 0.0 and 9.9)

- 5 Determine if the present tuning is valid. A signal level lower than 3 may indicate poor tuning if the sensor is filled with one of the preferred fluids (e.g. Kerosene). If this is the case we recommend returning to step #2 above and adjusting the tune setting upward or downward by 500 nT.

Once you have obtained signal a strength indicating adequate tune, you can begin your survey. If you wish to increase the signal strength, you will want to be more precise in selecting the tuning value. You might want to take a reading and enter the first three digits of that reading for the tuning value. Some trial and error is usually required to realize the maximum signal strength possible. In general, maximum signal strength is obtained when the tuning value matches that of the field. Signal strength levels of 6 to 10 are typical and should provide consistent measurement results.

5 - Automatic tuning

The G-856AX can be set to tune itself automatically. When the automatic tuning function is activated, the tuning value is automatically updated after each field reading unless a high gradient is present. To activate the automatic tuning function press:

AUTO, **TUNE**, **ENTER**

As this key sequence is pressed, something similar to the following displays will appear:

Auto 11	FIELD/TIME STATION/DAY
A tunE oFF	FIELD/TIME STATION/DAY

and automatic tuning will be turned on. **Note: While the automatic tuning function is enabled, the instrument cannot be manually tuned.** The tuning value and signal level may be displayed but they cannot be changed and attempts to manually tune the instrument will produce the following display:

A tunE Err	FIELD/TIME STATION/DAY
-----------------------------	---------------------------

To deactivate the automatic tuning function press:

AUTO, **TUNE**, **CLEAR**

The following displays will appear:

Auto 11	FIELD/TIME STATION/DAY
--------------------------	---------------------------

A tunE
on

FIELD/TIME
STATION/DAY

To determine the instrument's tuning mode press:

AUTO, **TUNE**

and observe the STATION/DAY display. It will indicate whether the Auto Tune function is on or off. For best performance, we recommend manual tuning of the G-856AX before taking the first reading in a survey area. After this, automatic tuning can be selected, and used with a better degree of confidence.

6 - Acquiring and storing a magnetic field reading

The **READ** and **STORE** keys are the only ones you will normally use while surveying. To measure the magnetic field, store it, and recall it from memory all that you need to do is press **READ**, **STORE**, and **RECALL** keys in sequence. You will observe something similar to the following:

- 1) When you depress **READ**, the displays will light briefly showing the battery voltage. For example:

batt
11.7

FIELD/TIME
STATION/DAY

- 2) Then, the battery voltage will turn off after a short interval and the **FIELD/TIME** display will light with a 5 or 6 digit number. For example:

67584.2

FIELD/TIME

This is the magnetic field reading in nT.

- 3) As the magnetic field appears in the **FIELD/TIME** display, another number appears in the **STATION/DAY** display. For example:

0

STATION/DAY

This is the station number. Both displays will stay lit for about 5 seconds and then go out.

- 4) To store the reading in memory, depress **STORE** while the displays are still lit. If the displays go out before you depress **STORE** the reading will be lost and the **ERROR** message will come on. Otherwise the display will go out after you press **STORE**.

The G-856AX can also be configured to store survey measurements automatically. In this mode you will only need to press **READ** in order for the console to read and store the measurement. To enable automatic storage press:

AUTO, **STORE**, **ENTER**

If you wish to revert to the standard manual store mode press:

AUTO, **STORE**, **CLEAR**

7 - Recalling measurements from memory

Magnetic field measurement values are stored sequentially in the console memory. A good way to visualize the console memory is to think of the data as being in a "stack" of lines, where each line is made up of 2 parts; the first part being the FIELD READING and STATION NUMBER and the second part being the TIME and LINE NUMBER or JULIAN DAY. The line number will appear if the reading was taken in Survey Mode. You will see the Julian Day if the reading had been taken in Automatic Mode. An example of the console memory structure is shown in Table 1 below.

Table 1. An example of the console memory stack.

<u>field</u>	<u>station</u>	<u>time</u>	<u>line no.</u>
67856.8	009	12.32.55	10
68645.5	008	12.32.30	10
68857.4	007	12.32.00	10
68682.9	006	12.32.54	10
68432.8	005	12.32.20	10
68845.7	004	12.31.59	10
68723.8	003	12.31.37	10
68245.6	002	12.31.02	10
68290.0	001	12.30.45	10

Console memory can be examined by pressing the **RECALL** key. When you do this the first half of the latest line in the memory stack will appear in the display. If the console memory contained the values shown in Table 1 then the console display would show the following:

67856.8	FIELD/TIME
009	STATION/DAY

If you press **RECALL** again, the memory decrements, and the next reading will be displayed:

68645.5	FIELD/TIME
008	STATION/DAY

Pressing **RECALL** will continue to decrement the memory and each reading in the sequence will be displayed. Pressing **ENTER** while the display is still lit will increment the memory. In a large stack of data, it is not necessary to keep depressing **RECALL** or **ENTER** until the desired reading is found. In cases where you wish to look at a particular reading (nn for example) you would press:

RECALL, **SHIFT**, 'n', 'n', **ENTER**

This key sequence will display the magnetic field measured in the FIELD/TIME display and the station number "nn" in the STATION/DAY display.

You can view the other half of the memory line (the time and line number) by pressing the **TIME** key while the first half of the memory line is being displayed. For the example shown in Table 1, pressing:

RECALL, **SHIFT**, '7', **ENTER**

Will recall the first half of the data stored for station 7 and generate the following display:

68857.4	FIELD/TIME
007	STATION/DAY

While this field measurement and station number are displayed, pressing **TIME**, will display the measurement's time and line number (or Julian Day, if the reading was taken in AUTO mode) as follows:

12.32.00	FIELD/TIME
010	STATION/DAY

While you are in the second half of the memory line, you can still decrement or increment by depressing **RECALL** or **ENTER**. You can also view the field measurement and station number by pressing the **FIELD** key while the display is lit

Some other features of the RECALL function include:

- There are two different methods of recalling the most recent station. You can: a) attempt to recall a station number that is greater than the most recent one or: b) press the **READ** without subsequently storing the measurement. Pressing **RECALL** after applying either of these methods will display the most recent stored measurement.
- Pressing and holding the **RECALL** key (or the **ENTER** key when in recall mode) will automatically scroll the display backward (or forward) through memory. This is a convenient means of quickly reviewing the measured field values.

8 - Erasing magnetometer readings

The G-856AX will allow you to erase the last reading, the last group of readings, or the entire memory.

1. To erasing just the last reading press:

READ, **RECALL**, **ERASE**, **ERASE**

In this key sequence, **READ** will position the memory pointer to the latest stored measurement and **RECALL** will recall it from memory. Pressing **ERASE** twice in succession while the displays are lit will erase the data for this last measurement record. This action will cause the displays to go blank indicating that the operation is complete. Note: **ERASE** must be depressed twice in order for the reading to be erased. This is a data protection feature. If **ERASE** is accidentally pressed, you can depress **CLEAR**, or any other key, to abort the erase operation.

2. To erase the latest group of readings:

First determine the station number where you wish to begin the erasure. All data will be erased from that station number to the last reading stored in memory. This is done by pressing:

RECALL, **SHIFT** 'n', 'n', 'n', **ENTER**, **ERASE**, **ERASE**

Where 'n', 'n', 'n', is the station number.

3. To completely erase all of the readings press:

RECALL, **SHIFT** '0', **ENTER**, **ERASE**, **ERASE**

This key sequence positions the memory pointer at the first station at the beginning of data memory and deletes all subsequent readings.

9 - Automatic reading set-up

Auto Mode allows the magnetometer to take readings automatically at a specified time interval. When the magnetometer is set up for automatic reading it is usually stationary, operating at a fixed location as a base station. The purpose of base station operation is to record the local temporal changes in earth's magnetic field so that these can then be used to remove the diurnal variation of the local magnetic field from the survey magnetometer's readings. In this way, the spatial variation of the magnetic field strength can be measured with greater accuracy and confidence.

The G-856AX is able to store about 12,700 readings in the automatic mode as compared to the approximately 5700 readings it stores in survey mode. The reason for this difference is that the reading time is not stored for each automatic reading. This can be done because the reading interval is known and this feature conserves memory space. In automatic mode, the G-856AX magnetometer can record as much as one reading every minute for over 200 hours. When recording in automatic mode, the three-digit number appearing in the STATION/DAY display will increment at 24:00 hours (midnight). This number should be set to represent the Julian (numerical) Day of the year. Note that this feature is not present in survey mode. In survey mode, the three-digit number doesn't increment automatically because it is most often used as a line number designator.

Before setting the G-856AX for automatic reading as a base station instrument, make sure that console's internal clock is set correctly. Then, to select automatic model and the reading interval press:

AUTO, **SHIFT** 'n','n','n', **ENTER**

The value "nnn" is the number of seconds between automatic measurements. You can examine the current measurement data while the G-856AX is operating in automatic mode. To do this press **RECALL** and **FIELD** - or **TIME** - as desired. The Julian day will be displayed if **TIME** is selected. Alternatively you can simply press **TIME** and the field/time display will light showing the current console time and the Station/day display will show the line number.

To shut off Automatic Mode, press:

AUTO, **CLEAR**

The displays will go blank and Auto Mode will be shut off.

The absolute minimum time required to obtain and store a reading 3 seconds. In order to set the magnetometer to cycle at 3 seconds, the "Display off after 5 minutes" and "Short Count Gate" functions must be set on the console's internal DIP switches. (See Table 4 in the Appendix for additional information.) If the selected cycle time is less than 10 seconds then there will be a slight delayed action when commands are keyed. This is because the console processor will be busy taking readings and displaying the results. You may find that you will need to hold down the **AUTO** key and then hold down the **CLEAR** key for one complete cycle in order for the command to be accepted.

Pressing the **OUTPUT**, **READ**, or **STORE** keys, or attempting to change the sample interval while the G-856AX is recording automatically will produce an ERROR message but will not affect operation in any other way.

10 - Retrieving magnetic field readings

Data can either be retrieved manually or automatically. To begin automatic data retrieval start by connecting the RS-232 serial download cable to the console. Next, plug the cable's opposite end into the serial port of your MS Windows computer. If your computer is not equipped with a serial port then it will be necessary to obtain an adapter that will allow connection of the serial cable; e.g. a serial to USB adapter.

We recommend using Geometrics MagMap2000 program to retrieve and process the data stored in the G-856AX. If you have installed this software you should run it now. (See the MagMap2000 operation manual or the Data Retrieval chapter for installation and specific operating instructions.) When prompted by MagMap2000, or when your computer is ready to receive data from the G-856AX press:

OUTPUT, **ENTER**

The information stored in the G-856AX memory, beginning with the first station number, will be automatically transmitted. The station number will flash so you can monitor the transfer process. If you need to stop the transfer process before it has completed press **CLEAR**. This will halt the data process but the data will remain in G-856AX memory until it is erased as described above.

You can also transfer just a portion of the stored data. To do this, press:

OUTPUT, **SHIFT** 'n','n','n', **ENTER**

The G-856AX will begin transmitting data from station number “nnn” to the last recorded measurement.

Field Operation

This section provides information about the G-856AX related to surveying technique and efficient operation in the field. It is recommended that the user become familiar with basic magnetometer operation as described in the preceding sections of this manual before attempting their first survey.

Sensor position and measurement repeatability

Measurement repeatability is important for verifying that the magnetometer is working correctly and that field conditions are have enough stability to insure that useful data can be collected. Repeatability is the demonstrated by obtaining the same measurement for several readings taken consecutively at the same position. The relationship between sensor position and repeatability is critical if a high degree of precision is required in this test. Repeatability will also be influenced by conditions at the measurement site. Conditions that are of particular concern include: high magnetic field gradients, large or rapid amplitude changes in the diurnal field, the presence of magnetic dust on the sensor and magnetic objects carried by the operator.

- **HIGH GRADIENTS:** In an area of 1 sq. meter where the magnetic field varies by less than 1 nT, you should expect less than 1 nT variation in repeatability. That is, changes in position by as much as 30 or 40 cm should not produce measurements that vary by as much as 1 nT. Under these conditions you might see changes of several tenths of an nT.
- **RAPID DIURNAL CHANGES:** Depending on solar and local thunderstorm activity, you might observe magnetic field changes even if the sensor is held perfectly still. A magnetometer like the G-856AX, with precision of 0.1 nT, will detect such temporal activity.
- **MAGNETIC DUST:** If dust or dirt has accumulated on the sensor it may be magnetically contaminated if this material is sufficiently magnetic. This material may noticeably affect the measurement results when the sensor is rotated. We recommend that the sensor and sensor cable be kept clean and dust free in order to provide the best survey results.
- **OPERATOR CONTAMINATION:** Steel-toed boots, a key ring, knife, pistol, GPS receiver or any other magnetic object carried by the survey operator can also become a source of errors in the magnetic data. In addition, if steel-clad batteries are installed in the instrument the console itself will almost certainly contribute to the magnetic field measured at the sensor. All articles carried by the operator should be considered suspect until they have been checked with the magnetometer. See the following section for the recommended magnetic screening procedure.

If the local gradient is very high the magnetometer will not be able to measure with its maximum precision. This is because the sensor signal collapses, or dies, before the count time of the measurement circuit has ended. The operator is alerted to this condition by a series of 5 quick beeps from the console and the operator will also observe that the measurement displayed is truncated: the magnetometer will not show the least significant digit on the display. Depending on the resolution you need, this may not be a problem. If high gradient is the cause, there is no need for 0.1 gamma resolution because the local magnetic field is changing very rapidly with position. A similar effect may be observed in very low fields. You can usually improve the signal strength by shortening the count time and/or lengthening the polarization time. (See the Appendix for information on the console's Internal Programming Switches for information on polarization time.)

Magnetic environment

Objects carried by the operator or that have been added to the magnetometer system can noticeably affect the total magnetic field measurement. Objects suspected to be magnetic should be checked in the following manner:

1. Mount the sensor on its staff, place the suspected article far away from the sensor, and take several measurements. Each measurement should repeat to ± 1 nT.
2. Now place the suspected article fairly close to the sensor (about $\frac{1}{2}$ meter) and again note the measurements.
3. Remove the article and again take several measurements.
4. If no diurnal shift is present then the first and third group of measurements will be within 1 nT of each other. You can assume that the test article is magnetic if the first group and the second group of readings varied by more than 1 nT.

The magnetometer will not operate reliably in areas that are near sources of strong radio frequency energy, where power lines and transformers are nearby, in most buildings, or near highly magnetic objects. The sensor should always be placed on the staff above the ground, or in the "backpack" if the console harness is so equipped. The sensor will NOT operate properly when placed directly on the ground.

Magnetic surveying

Standard operation

The typical survey geometry consists of a series of measurements equally spaced along a series of parallel lines. Usually the lines are positioned so as to form a rectangular area. This survey design insures that the measurement points (stations) will define a grid that samples the magnetic field strength at a uniform spatial density. An example of this survey geometry is shown in Figure 21.

The measurements acquired and stored in the G-856AX will be indexed according to a station number assigned by the magnetometer's processor. Station numbers are assigned sequentially as measurements are stored. If you use MagMap2000 to download and process the G-856AX measurements then there is some flexibility in the manner that you traverse the survey lines. That is, you can proceed in a bidirectional manner from one line to the next as shown in Figure 21. Alternatively, you can acquire measurements in a unidirectional fashion by always starting the next survey line at the same side of the survey area and visit each station while heading the same direction. As long as you proceed in a consistent fashion from one line to the next MagMap2000 will be able to locate the measurement points correctly.

For greatest measurement accuracy it is best to orient the sensor in the same direction at each station when acquiring the measurement. The same is true for the orientation of the operator: you should consistently position yourself in the same place, relative to the sensor, and face in the same direction. The technique will reduce the effects of any residual magnetization generated by the equipment or your personal effects.

As described in the Operating procedures section, the magnetic field is measured by simply pressing the **READ** key and is stored by pressing the **STORE** key. It is a good practice to try to remember the last several readings so that you can judge the validity of the current reading before storing it. If the current reading is in question do not press **STORE** – take another reading and store it if appears that its value is reasonable.

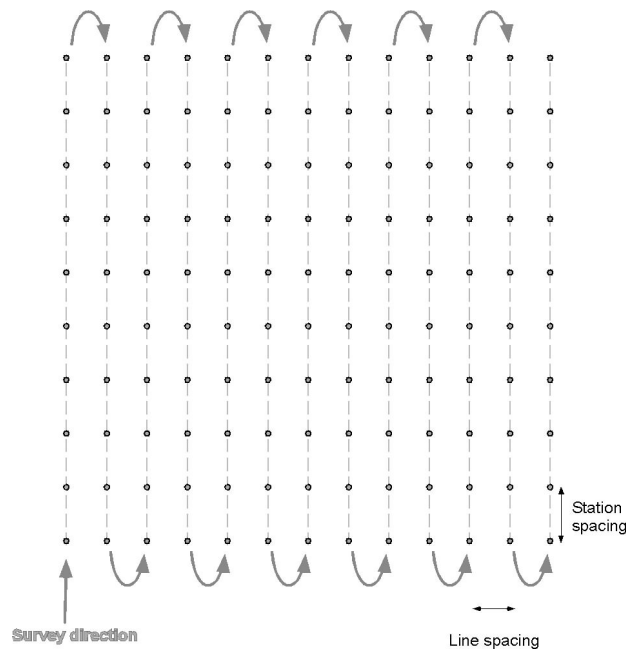

Figure 21, Typical survey layout.

Gradiometer operation

The survey layout and measurement accuracy considerations for a gradiometer survey are the same as for a standard, single sensor survey. The typical sensor separation between the two staff sections will be 4 ft. - comprising two staff sections. In this configuration the top sensor will be 8 ft above grade and the lower 4 ft above grade. This arrangement places the lower sensor closer to the operator and console than is the case with a standard single sensor survey. Because of this, we recommend that the gradiometer staff be held at a full arm's length when taking a measurement. This will position the lower sensor further from the console and operator and help to reduce their residual magnetic influence on the gradient measurement.

The G-856AX gradiometer operates in sequential mode. That is, a reading is first obtained from one sensor and then a reading is obtained from the other sensor. These two readings are separated by approximately three seconds and it is important to hold the gradiometer staff steady during measurement. Except in cases of local thunderstorm activity, there will be no temporal variation in the magnetic field that are detectable with the G-856AX over this three second delay period.

For gradiometer operation the G-856AX console should be configured for normal polarize, normal gate, 9600 Baud data transfer, and disable 3-read averaging by setting switches 1 through 4 to "off" and 6 through 8 to "on" on the G-856X CPU board. See Appendix section on Internal programming switches for details.

Base station operation

The typical location for a base station is near or within the survey area. The base station should be placed away from buildings, traffic, and power lines to provide the best results. Base station setup using Geometrics tripod is shown in Figure 16.

Base station recording is started by entering Automatic Mode. To do this press:

AUTO, **SHIFT** 'n', 'n', 'n', **ENTER**

To stop recording press:

AUTO, **CLEAR**

Data Retrieval

This chapter describes procedures for transferring data from the G-856AX console and describes the manual transcription of data if no PC computer is available. Before beginning retrieval of data, be sure to check that the console batteries have sufficient charge. Failure to do this could result in incorrect or incomplete data transfer. A simple test of the battery voltage can be performed by pressing **READ** when the sensor is not attached to the console. Under these conditions a voltage greater than or equal to 9.0 volts will indicate that there is adequate charge for trouble-free data transfer.

Computer connection and download

The G-856AX is designed to be used with personal computer running one of the MS Windows operating systems. Geometrics provides its MagMap2000 software to facilitate data download from the G-856AX and for processing the measurement results.

A serial download cable is included with the G-856AX. This cable is used to interconnect the magnetometer console's front panel connector with the serial port on a Windows PC. When you are ready to download data from the console connect the download cable to console's front panel connector and to the PC's serial port. (Note: some PC computers are not equipped with serial ports. If this is the case, you will need to connect an adapter – e.g. a USB-serial port converter)

We recommend that you use the MagMap2000 software supplied with the magnetometer to facilitate data retrieval and processing. To do so, under the MagMap2000 File menu item select "import G-856 data". A dialog box will appear that allows you to 1) select the computer's communication port that is connected to the magnetometer, 2) select the Baud rate, and 3) set the file name/directory for the data storage. When you have finished entering this information press the "DOWNLOAD NOW" button. Then on the G-856AX console press **OUTPUT** and **ENTER**. MagMap2000 should display a dialog box that shows the progress of data transfer from the magnetometer console to your computer

MagMap2000 offers many advantages. These include data download, profile plotting, filtering, contouring plotting and the diurnal correction of survey measurements using base station data. The latest version of MagMap2000 can be downloaded free of charge from our website (www.geometrics.com). The complete operating manual for this program is included in the software as an Adobe PDF document. If necessary you can download the free Adobe Acrobat Reader from www.adobe.com.

The following is a brief description of data download and processing using MagMap2000:

1. Download the G-856AX data using a RS-232 interface at 9600 baud. This takes about 10 minutes if the memory is full of survey data (5700 readings) or about 20 minutes if the memory is full of base station data (12,500 readings). The same

download procedure is used for single sensor, dual sensor (gradiometer) or base station configurations.

2. Define the grid and interpolate all data. MagMap2000 allows the user to define the spacing between discrete readings and between survey lines. Then the program assigns a position to each reading creating a uniform grid. Positions are editable individually or by line.
3. Search the data for spikes or erroneous readings and remove them using the options provided under the Filter menu item.
4. If desired, flag anomalies in the profile data that may be associated with targets of interest (archeological, environmental, utility, ordnance, geological, etc.). These flags will appear on the position map thus showing their location on the survey grid.
5. If desired create maps of the data as 2-D or 3-D plots with multiple color or shaded relief contours. These features are accessed by right-clicking on the map or survey line and selecting the desired output from the menu that appears. The Flags discussed in item 4 above are also reproduced on the 2-D and 3-D map data plots.
6. Survey results can be exported as a file in ASCII (Text) format for processing or plotting using other analysis programs such as Geometrics MagPick program, Geosoft or Surfer.

Manual Transcription

If no computer is available for data retrieval it may be necessary to simply archive the data with pencil and paper. To manually retrieve data, find the first reading in the survey (often 000) that was listed in your field notes or by iteration (see section The G-856AX can also be configured to store survey measurements automatically. In this mode you will only need to press **READ** in order for the console to read and store the measurement.

To enable automatic storage press:

AUTO, **STORE**, **ENTER**

If you wish to revert to the standard manual store mode press:

AUTO, **STORE**, **CLEAR**

7 - Recalling measurements from memory). After the first reading is found and data written down, depress ENTER to increment the magnetometer as many times as needed to see and hand record all the data. If you are retrieving data from a base station, you will be recording the data on the basis of measurement time rather than station number.

Maintenance

Instrument storage

When not in use, disconnect the sensor cable from the magnetometer console. We recommend storing all the components in the shipping case to help prevent magnetic contamination of the sensor or other system components. If the magnetometer system will be stored for a long period, remove the batteries to prevent electrolytic leakage or corrosion of the contacts. **DO NOT REMOVE THE LITHIUM BATTERY.** The lithium battery is soldered into the circuit board and will maintain data and system memory in the absence of the operating batteries. The recommended storage temperature for maximum battery life is 40°F (4°C). If you wish to store batteries for a long time, do so in a refrigerator. If batteries are stored in a refrigerator, wrapping the cells in a plastic bag will prevent condensation from collecting on them. After removing bagged batteries from refrigeration they should be allowed to warm up in the bag before being used.

Voltage indicator

After the **READ** key is pressed and before the magnetic field reading is displayed, a number indicating battery voltage appears in the FIELD/TIME display. The indicator will display BATT and a number showing the battery voltage. This number is the actual battery voltage present under load. That is, the battery voltage is measured during the polarize cycle of the magnetometer.

When operating from internal D-cell batteries, the maximum voltage will read around 13.5 Volts. Regardless of the battery type, when the indicated voltage reaches 8.2 Volts the magnetometer will stop polarizing. Under this condition the "Low Batt" message will be displayed and the batteries should be replaced or recharged.

If you continue to use batteries that have discharged below 8.2 Volts, the magnetometer may not respond to keyboard commands. Also, complete and accurate data retrieval cannot be assured if the batteries do not hold a sufficient charge. See the chapter on Data Retrieval for details.

If the G-856AX is powered from an external source the battery indicator may indicate a voltage higher than the 13.5 Volts. The maximum displayed voltage is 19.9 Volts and maximum recommended input voltage is 13.8 Volts.

Batteries

There are two kinds of batteries in the G-856AX. Basic operation is powered either by nine (9) internal D-cell batteries or by an internal rechargeable Gel-cell battery pack. A lithium battery that is soldered to one of the console's circuit boards powers the magnetometer's clock and internal memory. This lithium battery maintains clock and memory functions when the main batteries are disconnected or discharged.

At temperatures below 0° C, battery life decreases rapidly. At temperatures as low as minus 20°C operation may be limited to only 100 readings per set of batteries. At such low temperatures, a console that uses a rechargeable Gel-cell battery pack is preferable but, regardless of battery type, the console should be held close to the operator's person beneath the outer-most garment to take advantage of this insulation and the body heat of the operator.

D-cells batteries

When the magnetometer is used as a base station, alkaline D-cell batteries will work satisfactorily. Table 2 compares the expected number of readings expected for different battery types. Note that an optional external sensor power cable is available for base station use and it allows the user to connect the console to a 12v car battery. A typical fully charged car battery will last many days and this power configuration is often used when operating the G-856AX as a base station instrument.

When the G-856AX is used as a survey instrument, and is configured for operation from D-cells, we recommend using cardboard or plastic jacketed batteries. If steel jacketed batteries (carbon zinc or alkaline) are used in the console during survey operation a directional dependent shift of several nT may result and this will bias the measurement.

Table 2. Battery endurance comparison.

Battery Type	Brand Name	Number of Readings @25°C	Number of Readings @ 0°C	Jacket Type
Alkaline	Burgess, Eveready, Duracell	6000	4000	Steel
Standard Carbon-zinc (flashlight)	Burgess, Eveready, Ray-O-Vac.	1500	700	Cardboard
Premium Carbon-zinc	Eveready #1250	3000	1700	Cardboard
Internal Gel-cell	Power Sonic	Full Memory 12000	Full Memory 12000	Plastic

The values shown in Table 2 correspond to one reading every 30 seconds, using the 3-second cycle time setting (see Internal programming switches section in the Appendix). Faster sampling rates will yield less endurance, especially at lower temperatures. Photoflash and "Energizers" batteries are not designed for this type of application but may be used until other batteries are available. Battery capacity decreases rapidly below 0°C for most battery types but Photoflash and "Energizers" will recover when warmed above 0°C.

To remove and replace D-cells:

1. Unsnap the clasps and remove instrument cover.
2. Replace batteries to match the polarity markings on the battery holders.
3. Replace instrument cover. Be sure the cover is seated all the way down in the case before trying to close the clasps. Do not use the clasps to force the case into the case as this could cause breakage.

Gel-cell batteries

Their endurance and low magnetic signature make Gel-cell batteries the optimum choice for use with the G-856AX. The recommended procedure is to operate with the same Gel-cell battery set for the entire field day and place the partially discharged battery pack on charge at the end of the day. Overnight charging will insure that it is ready for use the next day. We recommend alternating operation between the two Gel-cell packs provided the magnetometer. In this way you are assured that you will always have two completely charged battery packs at the beginning of each workday.

Each battery pack should provide approximately 200 charge/discharge cycles with standard field use. Conditions that will reduce battery life include leaving the battery in a discharged state for long periods or exposure to below-freezing temperatures while in a deeply discharged state. Leaving them under charge for an extended period cannot damage the Gel-cell battery packs. When the system is not in use we recommend that its Gel-cell batteries be put on charge for at least 6 hours once every three months to preserve their service life.

Proceed as follows to change Gel-cell batteries:

- 1) Unsnap the side clasps and remove instrument cover.
- 2) Unplug the power connector from the battery pack. Do this by grasping each of the connector bodies and pull them apart.
- 3) Separate the Velcro band that secures the battery to the console chassis and remove the battery
- 4) Load the replacement battery in its slot and secure the Velcro band.
- 5) Reconnect the power connector.
- 6) Replace instrument cover taking care that the cover clears the Velcro bands and the power leads. Be sure the instrument is seated all the way down in the case before trying to close the side clasps. Do not use the clasps to force the unit into the case as this could cause breakage.

Lithium battery

In addition to the operating batteries, there is a AA-size lithium battery, called the "keep alive" battery, used to power the clock and preserve data memory when the operating batteries are removed. The lithium cell should be changed about every 6 to 10 years. It is soldered into and underneath the top circuit board. When the time has come to replace

the lithium cell be sure all survey data in memory has been recorded elsewhere before the lithium battery is unsoldered from the circuit board. Use the following procedure for its replacement:

1. Unclip the console cover and slide it off the case.
2. Remove the operating batteries.
3. Remove the four screws holding the circuit boards together. As you separate the boards, unplug the interconnecting cables noting their positioning as you do so. Lay the top circuit board down so the battery can be easily removed.
4. Unsolder the battery wires and wipe any debris from the battery area. Then carefully remove the battery so as not to damage the circuit board.
5. Check the battery polarity and then thread the positive lead of the replacement battery through the hole marked positive on the circuit board.
6. Measure the current drain from the battery if possible. Drain should not exceed 30 micro Amps. If the drain exceeds 30 micro Amps, the console should be repaired before being placed back in service. **WARNING:** Shorting the lithium battery will blow an internal battery fuse and could result in over heating and possible explosion. *Be sure the battery lead wires do not meet.*
7. Thread the negative lead of the battery through the hole marked negative.
8. Turn the board over and solder the lead wires to the pads. Trim off any extra wire. Connection is made with wires running through the center of the board.
9. Replace the circuit boards, cables, screws and cover.
10. Install the operating batteries. The clock will have to be reset after the battery is in place.

Sensor Fluid

The sensor contains coils of insulated wire and for optimum operation these coils must be submerged in a proton-rich fluid. The following section provides information about this fluid and the correct procedure for filling the sensor with fluid.

It is important that you DO NOT operate the sensor for an extended period without fluid as this can damage the sensor. The sensor should be filled so that the fluid level is about 1cm below the fill port. Correct fluid level can be checked approximately by shaking the sensor and judging the fluid level by the degree of sloshing. A more accurate level check requires removal of the sensor's fill plug and visual inspection of the contents. If the sensor is empty or needs filling proceed as follows:

1. Place the sensor on a flat, level surface.
2. Remove the blue cap plug on the sensor. Observe that the fill-port is a threaded tube extending into the sensor vessel. This design provides a 1cm air gap that allows for thermal expansion of the sensor fluid.
3. Fill with acceptable sensor fluid to within 1 cm. from the top. Acceptable Fluids for Proton Magnetometers include:
 - Shell SOL-71 (Shell Oil Co. product) *Note: This is the preferred fluid.*
 - Charcoal Lighter Fluid (Kingsford, Wizard, etc.)

- n-Decane (chemical supply houses, oil refineries)
 - ISOPAR-1 (Exxon Oil Co. product)
 - Odorless Mineral Spirits (also known as Naptha)
 - Kerosene
4. Pour only clear fluid into sensor. If fluid is dirty use a paper coffee filter or fine screen to eliminate particles.
 5. Slowly pour fluid into sensor until it is full. The sensor is full when the fluid just reaches the bottom of the fill-port.
 6. Place Teflon™ tape around the fill plug then screw it into the fill-port and tighten. Note: the fill plug and fill-port have tapered threads designed to form a tight seal. Tighten the plug just enough to prevent leakage - over tightening may damage the sensor housing.
 7. Sensor is now ready for use.

The different sensor fluids listed above will provide slightly different signal amplitudes but their use will ensure that the magnetometer measures the magnetic field strength correctly and that the sensor will not be damaged interaction with the fluid. *Geometrics does not recommend the use of gasoline (petrol) as a sensor fluid. Experience as shown that local formulation of gasoline may include additives that can damage the sensor. Do not put any solvent containing acetone or toluene into the sensor: these will dissolve the sensor body.*

Appendix

Magnetic field inclination (degrees)

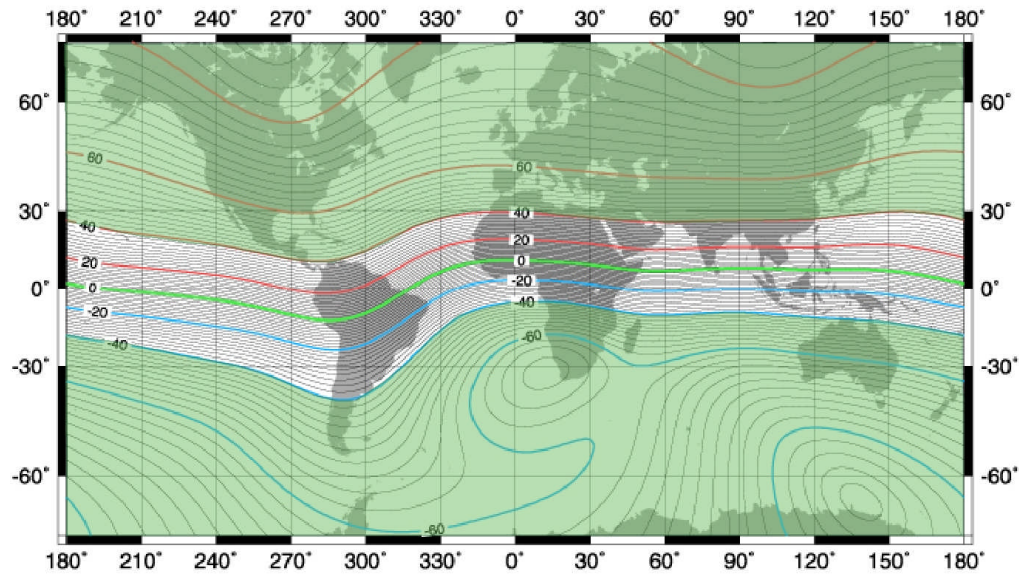

Magnetic field intensity variation (nT)

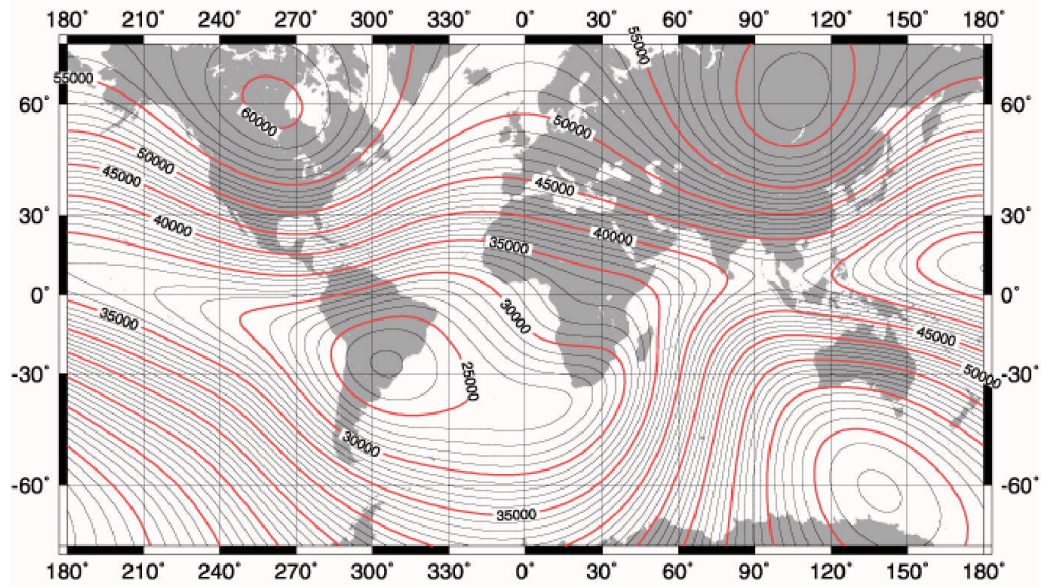

Troubleshooting

<u>Survey Difficulty</u>	<u>Probable Cause</u>	<u>Corrective Action</u>
Low Signal Amplitude (Display indicates less than 4 volts)	1. Magnetometer out of tune.	1. Retune magnetometer.
	2. Very high gradients.	2. Move out of the area or try switching to a short count.
	3. Broken sensor cable.	3. Replace or fix cable.
	4. Loss of sensor fluid.	4. Fill sensor with Shell SOL-71 to about 1/2 cm from the top.
	5. Sensor coil axis parallel to field.	5. Align sensor North-South or in the side-mount position.
Field display shows truncated digits (poor signal to noise ratio) and 5 beeps heard when reading taken	1. 50-60 Hz interference.	1. Move away from interference.
	2. Microphonic interference.	2. Avoid vibration mechanical shock to sensor while surveying.
	3. Broken sensor cable.	3. Replace or fix cable.
	4. High gradients.	4. See Erratic Readout.
	5. Generally weak signal.	5. Lengthen polarize time.
Erratic Readout	1. Magnetic storm or micropulsations.	1. Try later, especially at night.
	2. High geomagnetic gradient.	2. Hold sensor perfectly still. Try shortened count.
	3. Magnetic objects on operator.	3. Remove iron objects from pockets, belt, etc.
	4. Magnetic dirt on sensor.	4. Scrub or scrape magnetic particles off sensor.
	5. Review causes under "field display shows truncated digits."	
	6. Low battery voltage.	6. Replace batteries.
Displays do not light	1. Poor battery contact.	1. Check for loose batteries. Bend out contacts and clean.
	2. Low battery voltage	2. Remove batteries, then repress reset switch (SW2).
	3. Internal memory error.	3. Replace batteries.
No reading on STATION/DAY display	1. Inter-board cable not connected.	1. Check cable for proper connection.
Low Battery Voltage Indication	1. Low voltage.	1. Replace batteries.
Display reads "ERROR".	1. STORE depressed when no reading lit on the display.	1. Take new reading, press STORE before displays go out.
	2. FIELD depressed when depressing TIME did not precede it.	2. FIELD reading already displayed. The FIELD key is used to return to the first half of memory line. See Chapter 1, "Recalling from Memory".
	3. Incorrect or invalid key or key sequence depressed.	3. Consult Chapter 1. Depress key sequence again.
Display reads "data Err"	1. Internal memory error	1. Print out or transcribe all stored data, then depress ERASE , ERASE .

	2. Power removed while instrument was in operating mode.	2. Dump stored data into recording device, then press ERASE .
	3. Power interrupt during AUTO cycle or OUTPUT .	3. Remove batteries. Press the INTERNAL RESET button on CPU board. Install batteries. Set clock.
	4. Lithium battery malfunction.	4. Measure lithium battery voltage. If voltage is less than 3.2V, replace. (See page 30.)
	5. Control board malfunction.	5. Return board control board (P/N 16621) for repair.
Display reads FULL	1. Memory capacity is full of data.	1. Download or transcribe data and erase data to clear memory space.
Console will not tune	1. Poor signal-to-noise ratio. (See if display shows truncated digits.)	Seek quieter location.
	2. Low battery voltage.	2. Replace batteries.
Error message when tuning	1. Disable Auto-tune function.	1. Operating procedures: Auto-tune.
Partial numeric Display	1. Control board malfunctioning.	1. Return Control board (P/N 16621) for repair.

RS-232 interface

The Electronic Industry Association (EIA) established a standard to specify voltage levels and protocol for interfacing data-terminal and data communications equipment that uses serial binary interchange. The latest revision to this standard has been in effect since 1969 and is referred to as RS-232C. While RS-232C specifies a very complex group of data lines and signal levels, most devices equipped with interfaces called "RS-232C" in fact offer a subset of the standard as their interface method. The G-856AX is one such device.

The download cable provided for data transfer from the G-856AX is terminated with a 9-pin female D-connector. This cable, (P/N 16492-01), is wired to connect directly to the 9-pin serial port of a MS Windows PC. The following table lists the functions assigned to each pin of the pins used on this cable.

Table 3. RS-232 cable connector pin assignment.

9-pin connector RS-232	G-856AX front panel connector	Function
2	T	Transmit Data - from the G-856AX
5	D	Signal Ground - Zero reference for interface
7	G	Clear To Send - When low, inhibits G-856AX output. Leave open if not used.

The RS-232C standard specifies voltage levels and protocol for the data lines as $\pm 12V$ nominal, with voltages from 5V to 25V being acceptable. A logical "1" (mark, off or false state) is indicated when the voltage at the interface point is more negative than -3V;

a logical "0" (space, on or true state) is indicated when the voltage is more positive than +3V. RS-232 devices, including the G-856AX use 0 and +5 volts for these two logic levels ("TTL levels") instead of $\pm 12V$. Most devices designed to work with $\pm 12V$ levels will operate correctly with TTL levels but there are exceptions. Many large mainframe computers and some minicomputers require data over long cables. If your external equipment requires full $\pm 12V$ RS-232 levels, you will need to construct or purchase a TTL-to-bipolar interface driver.

Front panel connector pin assignment

Pin	Function	Remarks
A	Sensor	
B	Sensor	
C	Sensor shield	
D	Ground	Power and control ground
E	No connection	
F	Data accepted	Input from external device
G	Clear to send	
H	Battery positive	Connected to Internal Battery
J	Data 0	Serial BCD is no longer used
K	Data 1	Character
L	Data 2	Serial
M	Data 3	BCD out
N	Data valid	
P	End of data	
R	Instrument power	External Power in. Otherwise jumper to H
S	Synchronization	External read/store command
T	Transmit data	Part of RS-232
U	Receive data	

Output format

When attempting to transfer data from the G-856AX to a generic device, make sure that the baud rates of the magnetometer and device match and that G-856AX Txd line is connected to device's Rxd line. The G-856AX serial data format (RS-232) and BCD outputs are as follows:

- a. Each transmitted character is in ASCII code and consists of:
 - 1 start bit (always logic "1")
 - 7 data bits (ASCII encoded)
 - 1 parity bit (always logic "0")
 - 2 stop bits (always logic "0")

- b. Each line of data transmitted by the G-856AX consists of 29 ASCII characters. Listed in order, the data fields and their count is as follows:
 - Space or asterisk (*) - 1
 - Line number - 3

- Space - 1
 - Julian day - 3
 - Space - 1
 - Time - 6
 - Space - 1
 - Station number - 4
 - Space - 1
 - Field - 6
 - Carriage return, line feed - 2
- c. After all data has been transferred by the G-856AX, a final character (ASCII EOT) is transmitted.
- d. Transmission of data is initiated as follows:
- Press **Output**, **Enter**
 - Optionally you can press **Shift**, 'n', 'n', 'n', **Enter**; to begin output from station number "nnn".

External Power

The G-856AX may be powered from an external source. It will be necessary to operate from external power if the internal batteries are not sufficient for some nonstandard application such as: extremely cold weather operation, extended use of the magnetometer's three-reading average capability, long-polarize operation, or as a long term base station. The instrument may be run safely from a suitable external supply as high as 18 volts for improved signal to noise ratio. Note that the external power supply can be a source of interference if it is not well regulated and this may reduce signal quality.

To operation from external power, connect the positive terminal of the external source to pin R, and the negative terminal to pin D (ground). Alternatively you can obtain an external power/signal/data cable from Geometrics (P/N 16652-05). If you plan to construct your own external power cable we recommend including a 1.5-2 Ampere fuse in the power input line.

External magnetometer control

Momentary connection of pin S (SYNC) to pin D (Ground) at the front panel connector will set the magnetometer to take a reading and store it automatically. This feature is provided so that an external device can be used to control operation of the magnetometer and, if desired, synchronized the readings with some other device. This feature can be used to connect two G-856AX magnetometers so that their readings will be made simultaneously. In a small-area survey (most commonly used in archaeological and some engineering applications) a long cable can be run from the survey instrument to the base

station for more precise base station corrections. You could also interconnect two G-856AX magnetometers to create a portable gradiometer.

The external SYNC function can also be used to simplifying field operation. This would require the addition of a push-button switch wired between SYNC and Ground. Attaching the switch to the sensor staff will provide a convenient means of operating the magnetometer. This configuration will sacrifice the discretion of examining each datum before storing it, but will provide convenience. If an external switch is added to the magnetometer make sure that it is nonmagnetic.

The SYNC also has an output function. When the G-856AX starts a measurement cycle, either because **READ** was pressed or because the magnetometer is running in Automatic mode, SYNC is pulled low and held low until the end of polarize time, when it is released. If SYNC is pulled low externally, the measurement cycle is started. External SYNC may be momentary or many be held low indefinitely. If it is held low momentarily, polarization current will shut off at the normal time. If SYNC is sustained then the polarization current will flow until SYNC is released. In this manner two G-856AX instruments will be synchronized if their SYNC and ground pins are wired in parallel. Either instrument may provide the start command.

Internal programming switches

The G-856AX has a small programming switch located on the console's microprocessor circuit board. This switch is the 'dual in-line plastic' type and provides a set of eight individual switches as shown in Figure 22. Its settings allow the functional adjustment of the instrument to make it more noise insensitive, accurate, power efficient and better suited to your specific application.

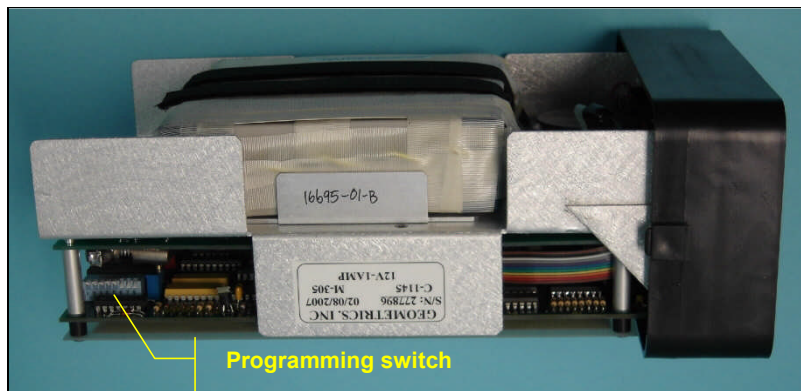

Figure 22. Location of console's internal programming switch.

To gain access to the programming switch, remove the instrument from its case just as you would to replace batteries. Look near the right rear corner on the top circuit board. You will find a rectangular switch with eight small levers. The switch is small and you

will need a small pointed object like a pencil tip to change the switch settings. Notice that the switch position are labeled 1 through 8 and that the ON position is identified by a dot or labeled 'ON' depending on the switch model. Typically, switches 1 through 5 are off and switches 6 through 8 are on. The functions of these switches and the operation state associated with their settings are summarized in Table 4.

Table 4. Summary of programmable switch settings.

Switches	Function	Settings			State
1, 2	Polarize time	S1 OFF	S2 OFF		Normal
		S1 ON	S2 OFF		Long
		S1 ON	S2 ON		Short
		S1 ON	S2 ON		Short
3	Read time	S3 OFF			Normal –920 ms
		S3 ON			Short – 460 ms
4	3 Reading average	S4 OFF			Normal
		S4 ON			Average
5	Auto cycle display	S5 OFF			Normal
		S5 ON			Display shuts off
6, 7, 8	Baud rate selection	S6 OFF	S7 OFF	S8 OFF	110 baud
		S6 ON	S7 OFF	S8 OFF	150 baud
		S6 OFF	S7 ON	S8 OFF	300 baud
		S6 ON	S7 ON	S8 OFF	600 baud
		S6 OFF	S7 OFF	S8 ON	1200 baud
		S6 ON	S7 OFF	S8 ON	2400 baud
		S6 OFF	S7 ON	S8 ON	4800 baud
		S6 ON	S7 ON	S8 ON	9600 baud

Polarize and count time – Switches 1 through 4

There are two stages in the process of obtaining a magnetic field measurement using a proton-precession sensor. During the first stage (polarize cycle), a current is fed to the sensor coil. This coil is immersed in sensor fluid and the current flow generates a magnetic field in this fluid that causes the spin axes of the hydrogen atom's protons to align. When the polarizing current is removed the protons precess about the ambient magnetic field and this precession frequency is counted for a short period of time (count cycle). There are tradeoffs in the amount of time provided for the execution of each of these cycles.

The polarizing current should be left on long enough to completely align the proton's spin axes (to produce a good signal precession signal), but not so long that battery power is wasted or the measurement time becomes inconveniently long. The count cycle should be relatively brief: the amplitude of the precession signal decays rapidly and it is best to obtain readings by counting its frequency early when the signal is strongest. Selection of the best counting period will depend on the polarization current, the ambient magnetic field strength, and the ambient magnetic gradient. High polarization current and/or high ambient magnetic field strength will produce more precession signal but high magnetic field gradient will cause the signal to collapse more rapidly.

Switches 1 through 4 adjust the polarize time and affect the sensitivity, speed, and power consumption of the instrument. Switch 1, when ON, will extend the polarize time from under two seconds to almost three seconds. Setting this switch will provide stronger precession signal, but will lengthen the total cycle time and thereby shorten battery life.

When Switch 2 is ON the polarize cycle period will be less than one second. This will speed up the cycle time and increase battery life, but will result in a weaker precession signal and this can result in reduced measurement accuracy.

When Switch 3 is ON the count cycle will be brief. This will speed up the cycle slightly, and will help to obtain good data under conditions where the precession signal might decay very rapidly - in areas of high gradients and low ambient field strength. When Switch 3 is ON, the resolution of the magnetic field measurement is reduced to 0.2 nT rather than the normal 0.1 nT. This switch should be set ON if the instrument is giving erratic or noisy readings.

When Switch 4 is ON the instrument will automatically take three readings and compute their average. This setting will provide high sensitivity but at the cost of significantly increased cycle time and power consumption. This setting is seldom used except when the G-856AX is used as a base station magnetometer operating on external power.

Near the magnetic equator, the Earth's magnetic field is relatively weak and many proton-precession magnetometers do not operate well, especially those models optimized for higher latitudes. In these areas the precession signal may be small and decay beyond detectability before the end of the count period. The solution to this problem is to extend the polarization time (switch 1 ON) and shorten the count time (switch 3 ON) so that counting is finished before the signal disappears. If you are surveying in areas with low ambient field strength you may find that setting switch 3 ON is sufficient to obtain good data. Otherwise you may need to also set Switch 1 ON as well. At low magnetic inclination you will also need to rotate the sensor into the saddle mount position in order to properly align the sensor with the ambient magnetic field.

When surveying in areas with large magnetic field gradients the effect is similar to that observed near the magnetic equator: the signal collapses before the end of the count. You will know you are in an area of high gradients when the display drops the least significant digit and you hear 5 quick beeps. The solution is the same as that for the low field strength near the equator – set Switches 1 and 3 ON.

Setting Switch 2 and 3 ON provides faster cycle time, longer battery life, and less sensitivity. This combination is recommended when maximum accuracy is not as important as speed and battery endurance.

To obtain greater sensitivity, Switch 1 (long polarize) should be ON. Setting Switch 4 (3-reading average) can also be set ON to improve the signal to noise ratio. Because of the length of the total cycle time needed to perform 3-reading averaging, this setting is most applicable to base station recording. Increased power is needed for long polarization

and/or the 3-reading average so it is best to use alkaline batteries, rechargeable batteries or external power when these functions are enabled.

SWITCH 5 - DISPLAY OFF AFTER 5 MINUTES AUTO CYCLE

If Switch 5 is turned ON, the display will blank if the keyboard is not exercised for five minutes. When you first set up the instrument, the display will light for five minutes to allow initial monitoring of the operation, but after you leave and those minutes have elapsed, the display will shut down to save power. If Switch 5 is OFF, the display will continue to light with each measurement cycle.

Switch 5 is applicable to the AUTO mode. On some occasions it will be desirable to have the measurements displayed as they automatically acquired. Such an occasion would be during surveys where the operator wishes to record automatically and also wants to monitor the data values. The AUTO mode is normally used for base station operation and here there is usually no reason to display the measurement values because the magnetometer is running unattended.

SWITCHES 6, 7, AND 8 (BAUD RATE)

Switches 6, 7 and 8 are used to set the baud rate. The RS-232 interface will output data at selected speeds (baud rate). Different types of devices can send and receive at different rates or combinations of rates. A mechanical Teletype with an RS-232 interface will receive at 110 baud. A standard telephone line with a modem will communicate at 300 baud or higher. Printers with RS-232 interfaces may handle 300 baud and higher. Computers can accommodate data transmission at 9600 baud and higher. The storage or printing device that you connect to the G-856AX will either have a specified baud rate or a selection of baud rates. You will want to use the fastest combination that is common to both the magnetometer and external device but the baud rate setting must be the same on both devices.

The data transfer rate in characters per second is approximately one/tenth the baud rate. A reading contains about 30 characters and includes FIELD, TIME, STATION NUMBER, DAY, LINE NUMBER, spaces, punctuation marks, carriage returns, line feed, and some null characters to allow time for a printer return to the start of a new line. This means that a single reading will require as much as three seconds to print on a slow telex machine, or as little as 1/5 of a second to transfer to a computer.

Internal Reset switch

There is a small red and white push button reset switch in between the circuit boards on the left hand side of the instrument chassis. The location of this switch is shown in Figure 23. In the event that the magnetometer's processor is not responding it may be necessary to reset the G-856AX. Care should be taken when using this switch as all data in memory and all internal settings such as the Clock and Cycle times will be reset to default settings. Make sure you attempt to download the data prior to using this switch.

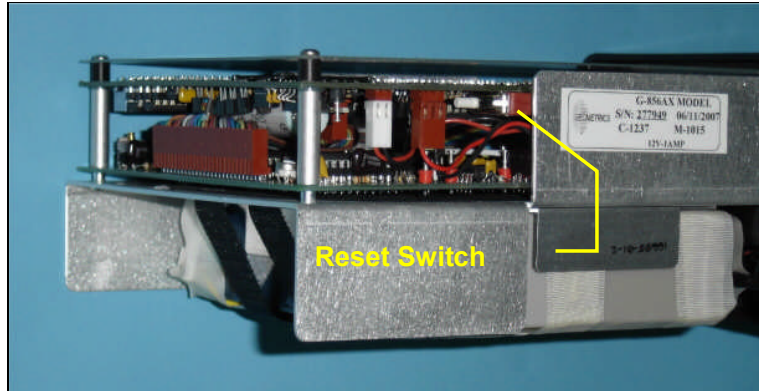

Figure 23. Internal reset switch.

Specifications

- Displays - Six digit display of magnetic field to resolution of 0.1 gamma or time to nearest second. Additional three-digit display of station, day of year, and line number.
- Resolution - Typically 0.1 gamma in average conditions. May degrade to lower resolution in weak fields, noisy conditions or high gradients.
- Absolute accuracy - One gamma, limited by remnant magnetism in sensor and crystal oscillator accuracy.
- Clock - Julian clock with stability of 5 seconds per month at room temperature and 5 seconds per day over the temperature range of -20 to +50 degrees Celsius.
- Tuning - Push button tuning from keyboard with current value displayed on request. Tuning range 20 to 90 μ T.
- Gradient - Tolerates gradients to 1800 gammas/meter. When high Tolerance gradients truncate count interval, maintains partial reading to an accuracy consistent with data.
- Cycle Time - Complete field measurement in three seconds in normal operation. Internal switch selection for faster cycle (1.5 seconds) at reduced resolution or longer cycles for increased resolution.
- Manual Read - Takes reading on command. Will store data in memory on command.
- Memory - Stores more than 5700 readings in survey mode, keeping track of

time, station number, line number day and magnetic field reading. In base station operation, computes for retrieval but does not store time of recording designated by sample interval, allowing storage of up to 12,000 readings.

- Output - Plays data out in standard RS-232 format at selectable baud rates. Also outputs data in real time byte parallel, character serial BCD for use with digital recorders.
- Inputs - Will accept an external sample command.
- Special - An internal switch allows:
 - adjustment of Functions polarization time and count time to improve performance in marginal areas or to improve resolution or speed operation
 - three count averaging
 - choice of lighted displays in auto mode.
- Physical -
 - Instrument console: 7 x 10 ½ x 3 ½ inches (18 x 27 x 9 cm), 6 LB (2.7 kg)
 - Sensor: 3 1/2 x 5 inches (9 x 13 cm), 4 LB (1.8 kg)
 - Staff: 1 inch x 8 feet (3cm x 2.5m), 2 LB (1kg)
- Environmental: Meets specifications from 1 to 40°C. Operates satisfactorily from -20 to 50°C.
- Power - Depending on version, operates from internal rechargeable Gel-cells or 9 D-cell flashlight batteries . May be operated from external power ranging from 12 to 18 volts external power. Power failure or replacement of batteries will not cause loss of data stored in memory.
- Standard system (P/N 16600-02) components:
 - Sensor (P/N 16076-01) and sensor cable (P/N 16134-01)
 - Console (P/N 16601-01)
 - Staff, one top section (P/N 16535-01), two middle sections (P/N 16536-01) and 1 bottom section (P/N 16537-01)
 - Carry harness (P/N 16002-02)
 - Two sets of rechargeable batteries (P/N 16697-01) and battery charger (P/N 16699-01)
 - Carrying case (P/N 16003-01)
 - Download cable (P/N 16492-01)
 - Hardcopy operation manual (P/N 18101-02)
 - Magnetometer CD (P/N 26648-01)
- Optional accessories:
 - Tripod kit for base-station operation (P/N 16708-02)
 - Gradiometer kit (P/N 166651-01)
 - Gradiometer carry/storage case (16003-01)

- D-cell battery console version (P/N 16600-02)
- 50' External power/data/sensor cable (P/N 16652-05)
- Low field base-station sensor (P/N 16194-01)
- Replacement lithium battery (P/N 40-202-005)
- Proton-precession magnetometer calibration tester (P/N 24840-01)

Warranty and service

Geometrics warrants the G-856AX be free of defects in material and workmanship for a period of one year. This warranty commences on the date of shipment. If the equipment fails due to manufacturing defects during the applicable warranty period, Geometrics, Inc. will repair or replace the defective item at its facility in California at no charge to the customer for parts and labor. The cost to ship the equipment to Geometrics, Inc.'s factory in San Jose, California and back to the customer's site is for the customer's account. Repairs might be done at a local service center, if available. Geometrics must be notified within 7 days of failure of the component for any warranty claim. Geometrics must establish to its satisfaction that failures have not been the result of abuse or improper use. The limited warranty stated herein is in lieu of all other warranties expressed or implied (including the implied warranties of merchantability and fitness for a particular purpose) and of all other obligations or liability on the part of Geometrics, and Geometrics neither assumes nor authorizes any person to assume for it any other liability. Geometrics shall not be liable for special, incidental or consequential damages of any nature (including, but not limited to lost revenue or profits) with respect to any merchandise or services sold, delivered or rendered hereunder. In the event of malfunction, Geometrics, at its own expense will repair or replace any material, equipment, work, or parts that prove defective or deficient under normal operating conditions.

In the event that warranty service or technical advice is required, contact Geometrics. No warranty service will be performed unless the customer secures authorization from Geometrics prior to returning equipment. If this instrument or any part of it is returned to the factory for any reason, please complete this form and include it with the instrument or part being returned.

Name: _____

Company: _____

Address: _____

City, State, Postal code, Country: _____

Telephone / email: _____

IMPORTANT

Please explain why this instrument or part is being returned; include a complete description of any malfunction (use additional paper if necessary).

SHIP TO: Geometrics Inc.
2190 Fortune Drive, San Jose, CA 95131
Phone: (408) 954-0522
Fax: (408) 954-0902

Declaration of Conformity

CE

03

San Jose, California, USA

DECLARATION OF CONFORMITY

We, Geometrics, Inc.
Geometrics Europe
2190 Fortune Drive
San Jose, CA 95131 USA
phone: (408) 954-0522
fax: (408) 954-0902

declare under our sole responsibility that our portable magnetometers, models G-856, and G-856G to which this declaration relates are in conformity with the following standards:

EN 55022: 1995, EN50082-2: 1995, ENV 50140: 1994, ENV 50141: 1994,
EN 61000-4-2: 1995, EN 61000-444: 1995

per the provision of the **Electromagnetic Compatibility Directive 89/336/EEC** of May 1989 as Amended by **92/31/EEC** of 28 April 1992 and **93/68-EEC, Article 5** of 22 July 1993.

The Technical documentation required by Annex IV(3) of the Low Voltage Directive is maintained by Christopher Leech of Geometrics Europe (address below).

The authorized representative located within the Community is:

Geometrics Europe
Christopher Leech
Manor Farm Cottage
Galley Lane
Great Brickhill
Bucks. MK17 9AB, U.K. ph: +44 1525 261874. FAX: +44 1525 261867



Mark Prouty, President
Geometrics, Inc.
San Jose, CA, USA